

by VELP Scientifica

Instruction Manual

CG-2024-10 Overhead Stirrer



General Information

 Before using the unit, please read the following instruction manual carefully.
Avant d'utiliser l'instrument, il est recommandé de lire attentivement le présent manuel d'instructions.

 Do not dispose of this equipment as urban waste, in accordance with EEC directive 2002/96/CE.
Ne pas recycler l'appareil comme déchet solide urbain, conformément à la Directive 2002/96/CE.

This unit must be used for laboratory applications only.

The manufacturer declines all responsibility for any use of the unit that does not comply with these instructions.

Cet instrument ne peut être utilisé que pour des applications de laboratoire.

Le fabricant décline toute responsabilité en cas d'utilisation non conforme aux instructions concernant ces instruments.

This unit has been designed and manufactured in compliance with the following standards:

L'instrument a été conçu et fabriqué conformément aux normes suivantes:

Safety requirements for electrical equipment for measurement, control and for laboratory use	IEC/EN 61010-1
Electrical equipment for laboratory use	UL 61010-1
General requirement - Canadian electrical code	CAN/CSA-C22.2 No.61010-1

VELP reserves the right to modify the characteristics of its products with the aim to constantly improving their quality.

Safety Regulations

The plug disconnects the instrument. Therefore, place the instrument where it can be quickly disconnected.

Le bouchon est le moyen de déconnexion de l'appareil. Par conséquent, placer l'appareil où il peut être rapidement débranché.

The values indicated on the rating plate of the instrument must correspond to those of the power supply.

Les valeurs indiquées sur la plaque signalétique de l'appareil doivent correspondre à ceux de l'alimentation.

Position the instrument on a flat surface, with a distance from the wall of 30 cm (at least).

Positionner l'appareil sur une surface plat, avec une distance de la paroi de 30 cm (au moins).

Fasten the unit to the support rod using the double clamp. Secure the receptacle using the ribbon clamp.

Fixez l'unité à le statif (A00001300) con le noix de fixation double (A00001301). Fixer le réceptacle à l'attache souple avec ruban (A00001302).

Safe working conditions are ensured only when the accessories described in the dedicated chapter are used.

Conditions de travail sûres sont assurées que lorsque les accessoires décrits dans le chapitre dédié sont utilisés.

The working speed set on the instrument must be such as to avoid wobbling and/or splashes. The unit must not be immersed in water.

Le nombre de tours de l'ensemble agitateur doit exclure les déséquilibres et les éclaboussures du produit agité.

Do not use the instrument in explosive environment or with dangerous substances. The unit must not be immersed in water.

Ne pas utiliser l'instrument dans des environnements explosifs ou de substances dangereuses. L'unité ne doit pas être immergé dans l'eau.

It is dangerous to run the unit with the stirring blade turning in free air.

Il est dangereux de faire fonctionner l'unité avec la lame d'agitation tournant à l'air libre. Toujours placer la tige d'agitation dans le récipient avant de mettre l'appareil en marche.

The unit is fitted with two fuses (2xT1,6 A L 250 V), found in the socket on the back. To replace one or more disconnect the mains cable and, using a screwdriver, lift up the small cover on the fuse box.

L'appareil est équipé de deux fusibles (2xT1,6 A L 250 V), qui se trouvent dans la douille placée sur le dos. Pour remplacer, débranchez le cordon d'alimentation et, à l'aide d'un tournevis, soulever le petit couvercle sur la boîte à fusibles.

It is responsibility of the user appropriately decontaminate the instrument in case of dangerous substances fall on or in it.

It is also responsibility of the user to use safety substances for cleaning or decontaminating, which do not react with internal parts of the instrument or with the material contained in it. In case of doubts on the compatibility of a cleaning solution, contact the manufacturer or local distributor.

Est responsabilité de l'utilisateur la décontamination en cas de déversement de matières dangereuses sur ou à l'intérieur de l'équipement. Est responsabilité de l'utilisateur à utiliser des substances qui ne produisent pas de danger pour le nettoyage ou de décontamination, qui ne réagissent pas avec les parties internes de l'appareil ou avec la matière qu'il contient. En cas de doute sur la compatibilité d'une solution de nettoyage, contactez le fabricant ou le distributeur local.

The solution may release toxic, dangerous or poisonous gases. Adequate safety measures must be taken, in accordance with the safety regulations in force, including the presence of hood and personal protective equipment (masks, gloves, goggles, etc.).

La solution peut libérer gaz toxiques ou dangereux. Des mesures de sécurité adéquates doivent être prises, en conformité avec les règlements de sécurité en vigueur, compris la présence de la hotte de laboratoire et équipements de protection individuelle (masques, gants, lunettes, etc.).

Contents

1. INTRODUCTION.....	2
2. ASSEMBLY AND INSTALLATION.....	2
2.1 ELECTRICAL CONNECTION.....	2
2.2 START-UP.....	3
2.3 INFORMATION ABOUT CONSTRUCTION MATERIALS.....	3
3. OPERATING CONTROLS.....	3
3.1 TORQUE INDICATOR.....	3
3.2 OVERLOAD PROTECTION.....	3
4. MAINTENANCE.....	3
4.1 CLEANING.....	3
5. TECHNICAL DATA.....	3
6. WIRING DIAGRAM.....	4
7. ACCESSORIES.....	4
8. WARRANTY.....	4
9. DECLARATION OF CONFORMITY CE	4

1. Introduction

Overhead stirrers are generally used for laboratory applications where the solubilization, mixing, suspension, emulsifying and homogenization of samples is required. CG-2024-10 overhead stirrers with electronic speed control and advanced safety features are able to satisfy the most diverse needs of the laboratory in terms of both viscosity and volume.

The chuck is keyless and ensures a secure and easy-to-fit mount for stirring shafts of up to 10mm in diameter. The stirring speed is controlled by a microprocessor and is constantly and automatically re-aligned to the set value even when there are variations in the viscosity of the liquid. Fluctuations in the voltage within the accepted range do not alter the quality of stirring speed alignment. The stirring time is controlled electronically, values of up to 999 minutes and 59 seconds can be set and the time remaining displayed on the LCD. The relative torque value can also be displayed.

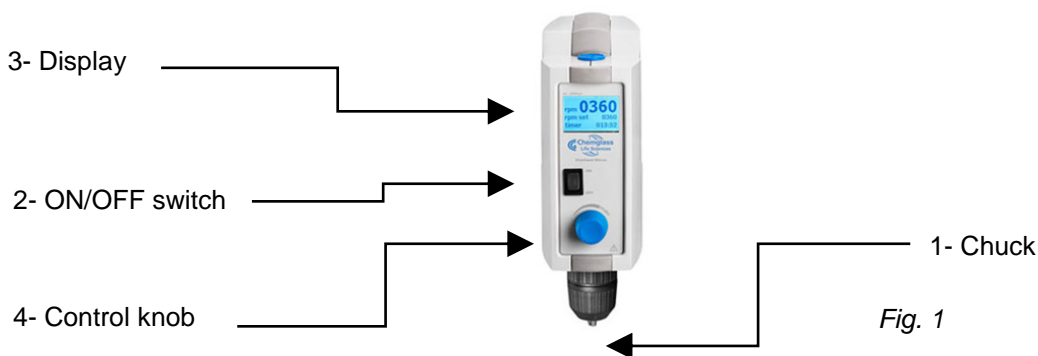

Fig. 1

2. Assembly and installation

Check the integrity of the unit after unpacking. The box includes:

- Overhead stirrer
- Instruction manual
- Allen key
- Allen head screw
- Shaft
- Power supply cable

2.1 Electrical connection

After unpacking the instrument, place the unit on the laboratory bench. Before connecting the instrument to the power supply, make sure that the values on the rating plate correspond to those of the power supply.

Ensure that the socket and the relative cut-off device conform to current safety norms and are easy to reach.

2.2 Start-up

Assemble the shaft using the Allen head screw. Fasten the instrument securely to the support rod with the double clamp. Secure the receptacle using the ribbon clamp to avoid damage.

2.3 Information about construction materials

Housing Die casting Polymer Structure Aluminum Control panel PET

3. Operating controls

Turn the unit on using the mains switch. After a few seconds the instrument model and the software version will appear on the display. When the instrument is in use the graphic display shows the real chuck speed (rpm) and the set speed (rpm set). Speed and time functions are controlled by an encoder. Turn the control knob to select stirring speeds of from 50 to 2000 rpm. Press the control knob to activate the timer and turn the knob to select the stirring time. Stirring times of up to 999:59" can be selected. Press the control knob to start count-down. At the end of the set time stirring stops and "END" will appear on the display.

NOTE: The speed setting is saved when the instrument is turned off or if there is a power failure. When the instrument is turned on again, the value flashes for approximately 8 seconds before stirring starts. During this time the speed setting can be changed using the control knob.

3.1 Torque indicator

Keep the control knob pressed for approx. 3 seconds to display the torque trend value, i.e. the value in Ncm of the effective torque on the stirring shaft .

To reset the torque value and measure the relative torque, keep the control knob pressed for approx. 3 seconds.

NOTE: The torque value indicated is not an absolute value. The reading indicates the variation in the torque value compared to a set value defined by the operator. The most precise torque trend values are obtained once the instrument has reached the optimum working temperature. Optimum time 10-15 minutes.

3.2 Overload protection

The current and voltage are electronically limited in order to safeguard the motor and the electronic parts against electric surges. In the event of abnormal conditions arising the following error messages appear on the display and the unit shuts down automatically.

Over Load Current surges

The stirrer can compensate for eventual current surges for a limited period of time in which case the following symbol appears in the top rh corner of the display . If the situation persists, the speed of the motor is gradually reduced. When a speed of 0 is reached "OVERLOAD" appears on the display and the unit shuts down.

Over Curr Rpm error

This error message is displayed if the chuck is accidentally blocked or if the number of revs exceeds the permitted value.

Over Temp Temperature error

This error message may appear if the unit is used for heavy-duty work for prolonged periods of time and at an ambient temperature that exceeds the max. permitted temperature. Before resetting the instrument allow it to cool down.

Over Volt Voltage surge

The software limits the power supply of the motor to the nominal value of the motor itself (60V). A high speed setting or a heavy load on the chuck may prompt a higher voltage. In this case the voltage is limited to the nominal value of the motor (60V) and the number of revs is reduced accordingly. In these conditions the following symbol appears in the top rh corner of the display . If for any reason the power supply of the motor exceeds the maximum threshold value of 70V, "OVERLOAD" will appear on the display and the unit will shut down.

NOTE: To reset the unit remove the load from the chuck and turn the unit off and on again using the mains switch.

4. Maintenance

No routine or extraordinary maintenance is necessary apart from periodically cleaning the unit as described in this manual. In compliance with the product guarantee law, repairs to our units must be carried out in our factory, unless previously agreed otherwise with local distributors.

4.1 Cleaning

Disconnect the unit from the power supply and use a cloth dampened with a mild, non-flammable detergent.

5. Technical data

Admitted power supply	From 110 to 230Volt 50/60Hz
Max. input / output power	190W / 280 W
Dimensions (WxHxD)	80x230x196 mm (3.1x9.0x7.7 in)
Weight	3 Kg (6,6 lbs)
Speed range at nominal load	50 – 2000rpm
Speed indicator / resolution / accuracy	LCD / 1rpm / ± 10 rpm ≤ 300 rpm; $\pm 5\%$ >300 rpm
Max torque stirrer shaft / accuracy	80Ncm / ± 5 Ncm

Timer with automatic cut-off	From 000':00" to 999':59"
Max stirring quantity H ₂ O	40 litres
Clamping chuck clamping range	From 1 to 10mm
Overload and overtemperature protection	Automatic cut-off
Enviromental / Storage ambient temperature	5 - 40°C (41 - 104°F) / -10... + 60°C (14 - 140°F)
Max humidity	80%
Noise Level	<<80dBa
Operating mode	Continuous
Overvoltage category CEI-EN 61010-1	II
Pollution degree / installation cat. CEI-EN61010-1	2
Max altitude installation	2000m (6561 ft) asl
Fuse diam. 5x20mm	2xF1,6A L 250V

6. Wiring diagram

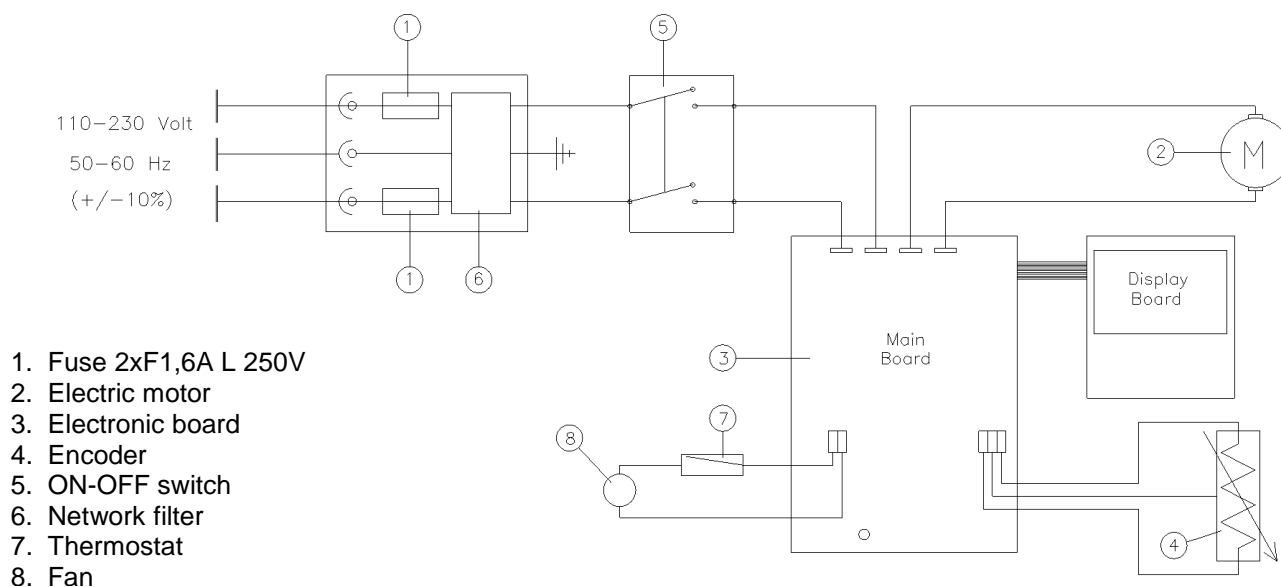

7. Accessories

Please get in contact with Chemglass Life Sciences for more details about accessories.
www.cglifesciences.com Phone: 1-800-843-1794

8. Warranty

The unit is guaranteed against production defects for 36 months from our invoice date.

In accordance with this guarantee Chemglass Life Sciences undertakes to repair any units resulting as faulty due to the quality of the materials used or poor workmanship.

Units rendered faulty due to inexpert handling/use or carelessness will not be replaced or repaired under warranty.

Exclusions:

The guarantee will be considered null and void for faults resulting from:

- inexperience and carelessness of the operator
- repairs, maintenance or replacement of parts carried out by personnel or Companies not authorized by the manufacturer
- use of the instrument that does not comply to the instructions/recommendations given in the present operating manual
- use of non-original spare parts.

9. Declaration of conformity

We, the manufacturer VELP Scientifica, under our responsibility declare that the product is manufactured in conformity with the following standards:

EN 61010-1 (2001) - EN 61010-2-051 (2003) - EN 61326-1 (2013) - 2011/65/EU (RoHS) - 2012/19/UE (RAEE) and satisfies the essential requirements of the following directives:

- Machinery directive 2006/42/EC
- Low voltage directive 2014/35/EU
- Electromagnetic compatibility directive 2014/30/EU
- plus modifications