

ASSEMBLY INSTRUCTIONS FOR CG-1968-W6150; 150L JACKETED PROCESS REACTOR SYSTEMS

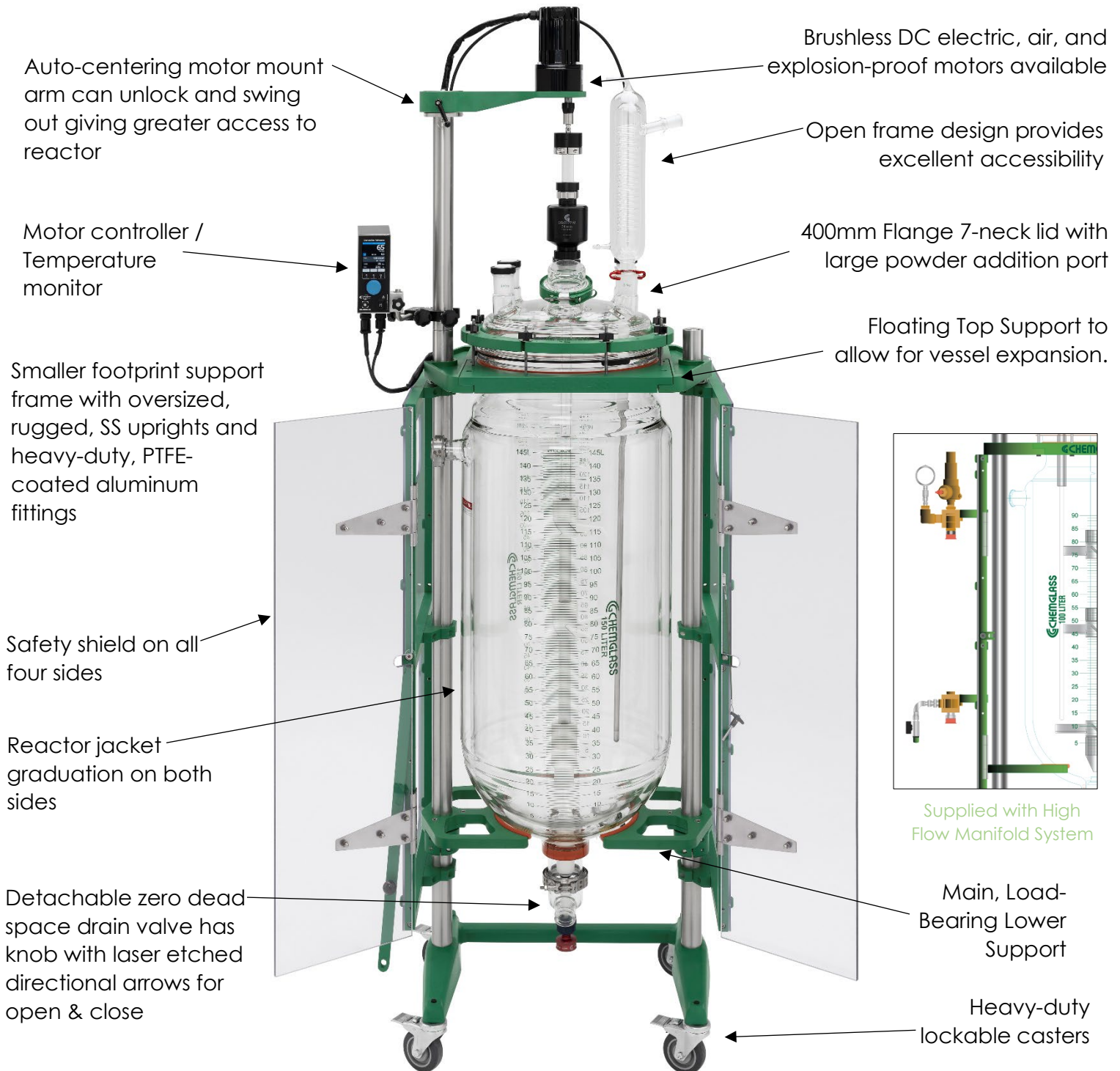

Read Entire Assembly Instructions Before You Begin. Familiarize Yourself with All of the Parts, and Pay Close Attention to All Notes and Highlights.

Support frames are shipped via common carrier and require loading dock access with a fork lift or jack. If you do not have a loading dock, then a lift gate-equipped truck must be requested at the time of order.

For your convenience, the jacketed process reactor, the fully assembled reactor head, stirrer shaft & agitators, PTFE stirrer bearing, temperature probe & adapter, high flow manifold blocks, and safety shields are shipped assembled on the support frame. PTFE sleeves and keck clips are available separately.

Unpack all of the parts and check against the packing slip to make sure you have received all necessary components. If possible, keep some of the packaging materials from the wood crates in case you need to return items for repair or replacement.

Crate # 1:

- Unpack the lower half of the support frame with the reactor and components by removing the packing material from around the reactor. Retighten all Allen screws with supplied wrenches. **CHECK ALL ALLEN SCREWS BEFORE PROCEEDING. SCREWS CAN LOOSEN DURING SHIPMENT.**

Crate # 2:

- Contains the upper universal motor mount, 3/8 HP electric stirrer motor, condenser, zero dead space drain valve, motor controller/temperature monitor, and other miscellaneous parts.

Move the reactor assembly and parts near the hood or area where the reactor will be used, but allow enough space to move freely around the support frame. During setup, preparation, and process, it is best to keep the wheels in their locked position by stepping down on the tab. Begin by attaching the upper universal motor mount arm to the lower half of the support frame that houses the reactor. Tighten all Allen screws with supplied wrenches.

Universal Motor Mount Arm

The mount is shipped assembled but must be attached to the lower portion of the support frame. Tighten all Allen screws with supplied wrenches.



Overhead Stirrer Motor



3/8 HP Vertical Motor



Explosion Proof (XP) Motor

The motor is installed on the support frame when shipped. Use the following instructions should you need to remove or adjust these components.

Components Needed for Overhead Stirrer Motor:

- 1ea CG-2033-B-39 3/8 HP Vertical Electric Stirrer Motor
- 1ea CG-2033-V-75 Motor Controller/Temperature Monitor (Only Supplied with 3/8 HP Electric Stirrer Motor)
- 1ea CG-2046-X-130 Stirrer Shaft Split Coupling
- 1ea CG-9253-20 Large Kwik Klamp II
- 1ea CG-3498-03 90° Support Rod

1. The support frame has a universal motor mount. It can be used with an electric, air, or optional explosion proof (XP) motor. The mount automatically centers the motor directly above the reactor. **PLEASE NOTE: IT MAY BE EASIER TO FIRST ATTACH THE MOTOR TO THE UPPER UNIVERSAL MOTOR MOUNT ARM, AND THEN PLACING ABOVE THE REACTOR.**
2. Attach the 3/8 HP electric motor to the universal motor mount arm via four socket head cap screws. Screws are shipped installed on the motor.
3. Lower the motor mount (with motor securely attached) in to place and tighten all Allen screws.
4. Attach the stirrer shaft coupling to the motor shaft.
5. When using the 3/8 HP electric motor, the motor controller/temperature monitor with the mounting bracket on the side, needs to be mounted on a S.S. upright. Use the large Kwik Klamp II and 90° support rod to mount the controller to the support frame. Tighten all knobs securely.

Stirrer Shaft and Agitator Assembly

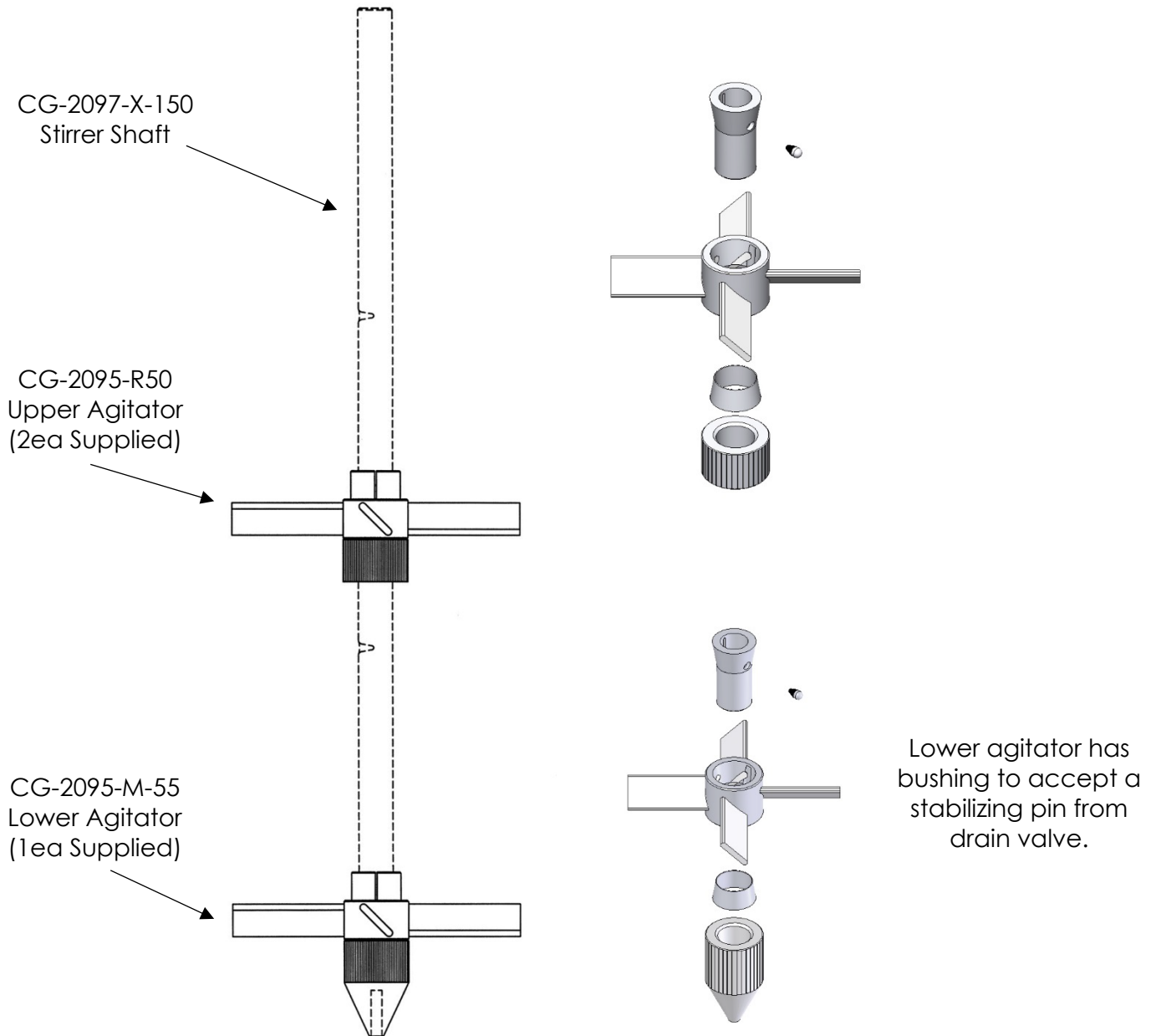

The stirrer shaft and agitators are assembled and installed when shipped. Use the following instructions should you need to remove or adjust these components.

Components Needed for Stirrer Shaft and Agitator Assembly:

- 1ea CG-2097-X-150 Stirrer Shaft
- 2ea CG-2095-R50 Upper PTFE Agitators
- 1ea CG-2095-M-55 Lower PTFE Agitator with Stabilizing Bushing

1. The lower agitator assembly is placed on the end of the stirrer shaft. The sand blasted portion is the lower end of the stirrer shaft.
2. The upper agitator assembly slides over the end of the shaft. The stirrer shaft has indents that are spaced every 10 inches from the bottom for the CG-2095-M-55 agitator, for positioning. Set screws on the agitator must be aligned with the indents on the stirrer shaft.

Required Ceiling Height

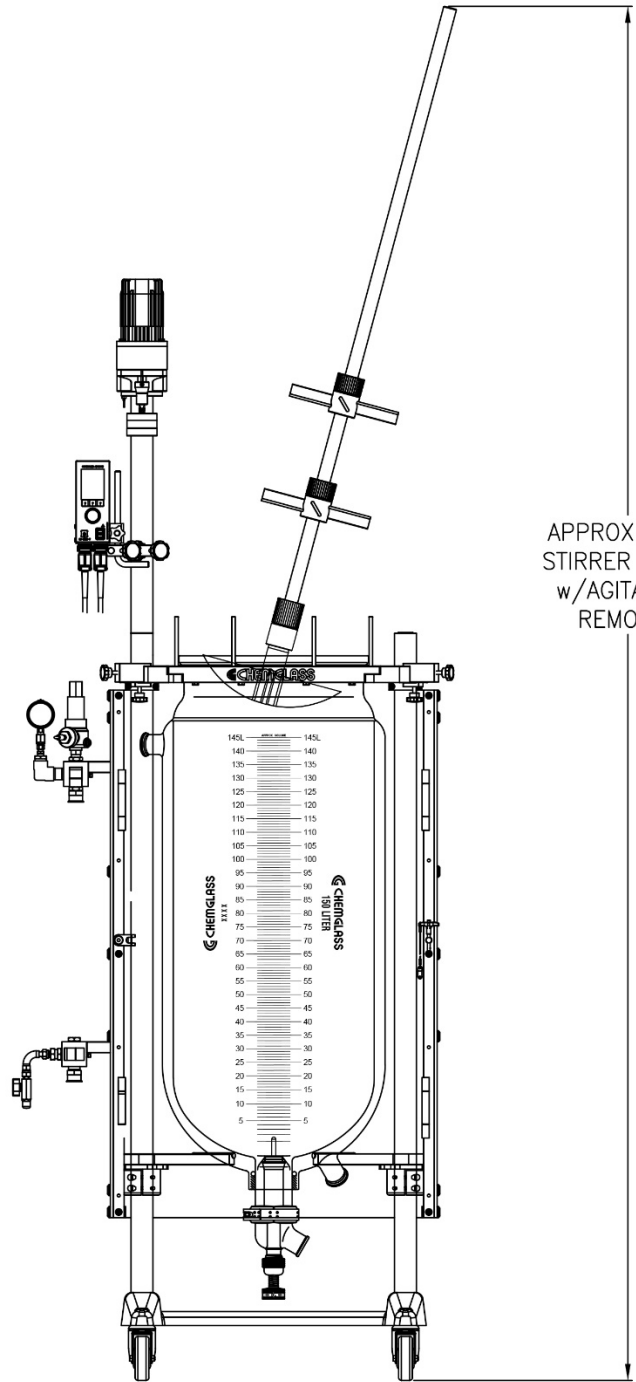
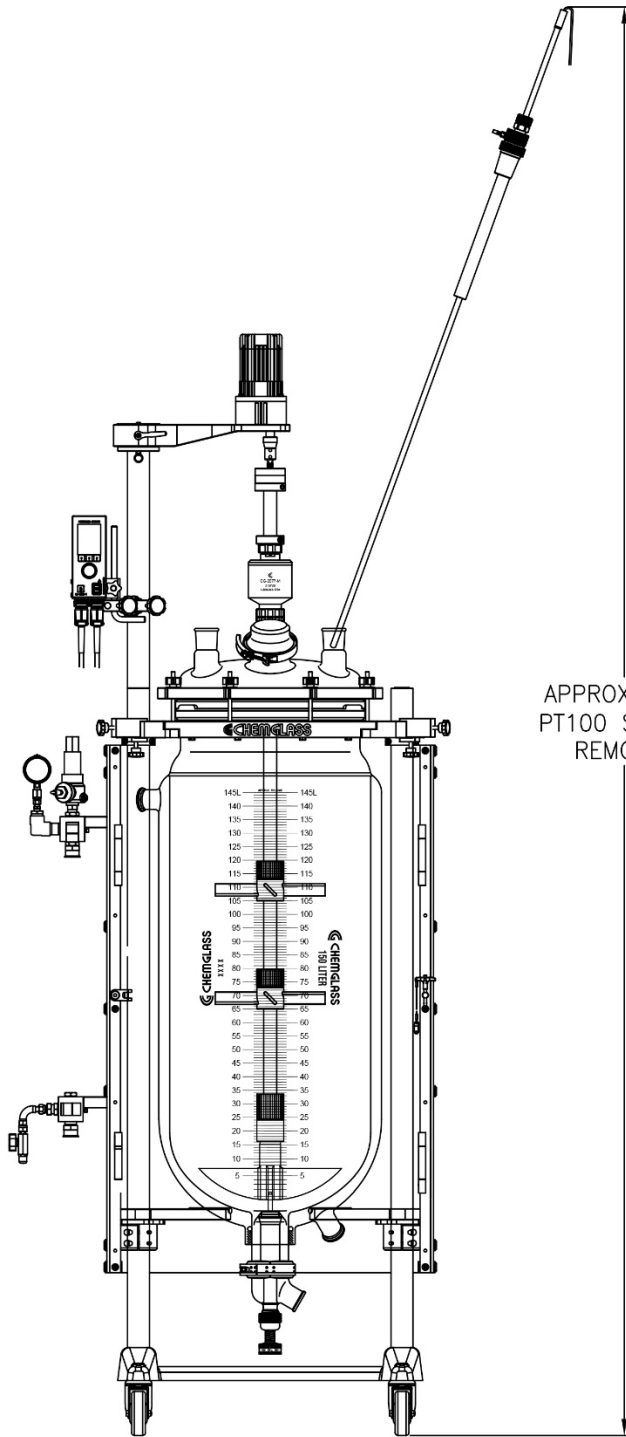

Inlet/Outlet Jacket Connections



3/4" ID Triple Insulated Flexible Hose has welded-on S.S. beaded pipe fitting for direct connection to inlet/outlet. Opposite end is a 3/4" Male NPT for connection to manifold block.

Outlet
Manifold

Inlet
Manifold

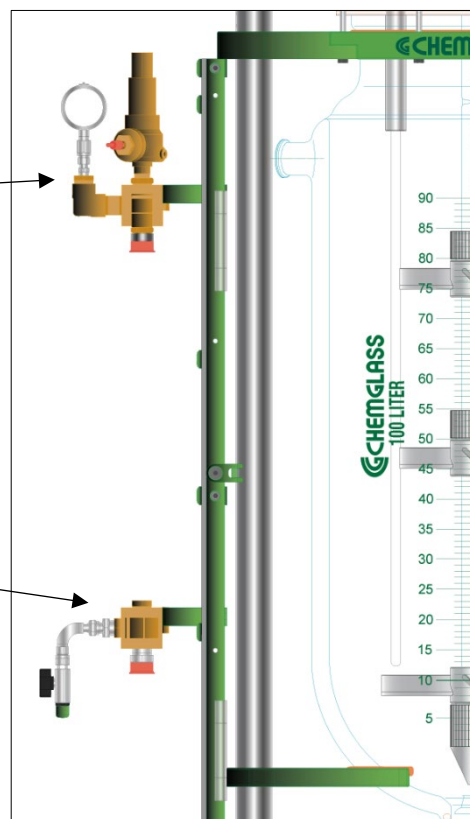

The high flow manifold system and triple insulated flexible hoses are assembled and attached to the inlet/outlet jacket connections when shipped. Use the following instructions should you need to remove or adjust these components.

Components Needed for Inlet/Outlet:

- 1ea CG-1969-M High Flow Manifold System
- 2ea CG-1968-69 1-1/2" Beaded Pipe Couplings

Inlet Manifold:

1. Attach the supplied 3ft green triple insulated hose to brass elbow on manifold block.
2. Mount the inlet manifold to right S.S. upright.
3. Attach the hose to the reactor inlet using a beaded pipe coupling (sold separately). Tighten the beaded pipe coupling to 50in-lbs using a torque wrench.
4. Attach circulator hose (sold separately) to bottom of inlet manifold block via the M16 or M30 thread. Hand tighten plus 1/4 turn with wrench.

Outlet Manifold:

1. Attach the supplied 4ft long triple insulated flexible hose to port of manifold block.
2. Mount outlet manifold to right S.S. upright.
3. Attach the hose to the reactor outlet using a beaded pipe coupling (sold separately). Tighten the beaded pipe coupling to 50in-lbs using a torque wrench.
4. Attach circulator hose (sold separately) to bottom of outlet manifold block via the M16 or M30 thread. Hand tighten plus 1/4 turn with wrench.

TEMPERATURE LIMITATIONS ON MANIFOLD = -60 TO 200°C
MAX JACKET PRESSURE = 12 PSI* ON 150L JACKETED REACTOR CG-1968-W6150

(* double check the PSI decal on your reactor)

MAX Δ T = 60°C

TEMPERATURE RANGE = -60 to 200°C

Zero Dead Space Drain Valve



Components Needed for Zero Dead Space Drain Valve:

- 1ea CG-1968-T-55 Zero Dead Space Drain Valve with Stabilizing Pin
- 1ea CG-1968-T-75 3" Beaded Pipe Coupling

1. Loosen the nut on the 3" beaded pipe coupling. Wet the PTFE/Viton liner inside the coupling and attach on side to the 3" beaded pipe drain valve seat on the reactor.
2. Attach the drain valve assembly to the other side of the coupling. The stabilizing pin should be slide into the alignment bushing on the lower PTFE agitator when valve is in the closed position. **PLEASE NOTE: PLUG MUST BE IN THE OPEN POSITION WHEN ATTACHING TO THE COUPLING. AFTER ASSEMBLY, BE SURE THE PLUG IS IN THE CLOSED POSITION PRIOR TO FILLING THE REACTOR.**
3. Tighten the 3" beaded pipe coupling to 75in-lbs using a torque wrench.

BEFORE YOU START:

The reactor is now ready for use. Before filling the reactor, make sure the zero dead space drain valve is in the closed position. Once setup is complete, the reactor can be moved into position and connected to the circulator. Keep the wheels locked for added safety.

Chemglass presumes some knowledge of this type of equipment on the part of the end user. Properties such as mechanical strength of glass, thermal stress introduced to the reactor from exothermic reactions, allowable temperature differentials, pressure and vacuum must all be considered with extreme caution.

If you have any questions, please contact our technical service department at (800) 843-1794 or technical-service@cglifesciences.com.

WARNING: PLEASE NOTICE TEMPERATURE LIMITATIONS ON O-RINGS LISTED BELOW BEFORE USING THIS VALVE. PLEASE USE THE CORRECT O-RING FOR THE TIP BASE ON YOUR APPLICATION TEMPERATURE.

<u>O-Ring Material</u>	<u>Color</u>	<u>Temp Range (°C)</u>
Perfluoro	Black or White	-7 to 230
FEP-Silicone	Orange	-62 to 205

150L System with 400mm Flange & Shield

CG-1968-W6150

Complete System with Standard Components listed in the table below.

No.	Qty.	Part No.	Description
1	1	CG-1215-C-02	High Efficiency Condenser, 45/50
2	1	CG-2097-X-150	30mm Stirrer Shaft, Solid Top, Lower Portion Sandblasted, with Indents
3		CG-2048-04	30mm Stirrer Shaft Retainer, Nylon, Safety
4		CG-2077-M-05	31mm Mechanical Seal Stirrer Bearing
4a		CG-2077-M-33	31mm Lower Joint Adapter, 45/50
5	1	CG-1968-E-400	400mm Reaction Vessel Lid, 7-Neck, 45/50 CN, 5-45/50 SN, 1-Angled 80mm Flat O-Ring Flange SN
—	3	CG-3002-L-45	Stopper, PTFE, 45/50 with Loosening Ring
6	1	CG-145-09	Clamp, Keck, Brown, Standard Taper, Fits Joint Size 45/50, 10 / Pkg
7	1	CG-149-06	80mm Glass Cap
8	1	CG-147-81	O-Ring, Perfluoro, 80mm Flange White
9	1	CG-141-T-10	80mm Quick Release Clamp, PTFE-Coated
10	1	CG-1968-H-02	Perfluoroelastomer Gasket, 400mm
11	1	CG-1968-W150	150 Liter Reaction Vessel, Large Scale, 3" Beaded Pipe, Detachable
12	1	CG-1968-T-55	3" Beaded Pipe, Zero Dead Space, Drain Valve with 1 1/2" Beaded Pipe Sidearm
13	2	CG-1968-69	1 1/2" Beaded Pipe Coupling
14	1	CG-1968-T-75	3" Beaded Pipe Coupling
15	1	CG-2033-B-39	3/8 HP Brushless DC Motor Only, 24v, 3/4" Shaft Diameter
16	1	CG-2033-V-75	Controller, Motor, Temp. and Time, Only for Brushless DC Motor, 120v, WiFi
17	1	CG-2046-X-130	30mm Stirrer Shaft Split Coupling
20	1	CG-1978-P1150	PT100 Temp. Probe, 1/2" Dia. x 60" Long
21	1	CG-1971-88	45/50 PTFE Thermocouple Stabilizer, Complete with 1/2" Pipe Probe
22	1	CG-3498-03	90° Support Rod, 1/2" OD, Stainless Steel
23	1	CG-9253-20	Large Kwik Klamp II, Hardcote & PTFE Anodized Finish
25	2	CG-2095-R50	10" Diameter Upper Agitator, PTFE
26	1	CG-2095-M-55	13" Diameter Lower Agitator, PTFE, with Stabilizing Bushing
27	1	CG-1968-Z-150	Open Air Support Frame with Safety Shield Assembly, 28.25" W x 20" D x 92" OAH, with High Flow Manifold
—	1	CG-1963-B-10	Beam Torque Wrench
—	1	CG-1963-B-15	1/2" Deep Socket, 6 Point, 1/4" Drive
—	1	CG-1963-B-14	7/16" Deep Socket, 6 Point, 1/4" Drive

Motor Type	Approx. Overall Height with Motor (in.)	Clearance Below Drain Valve Side Arm (in.)
Electric	100.1	12.1

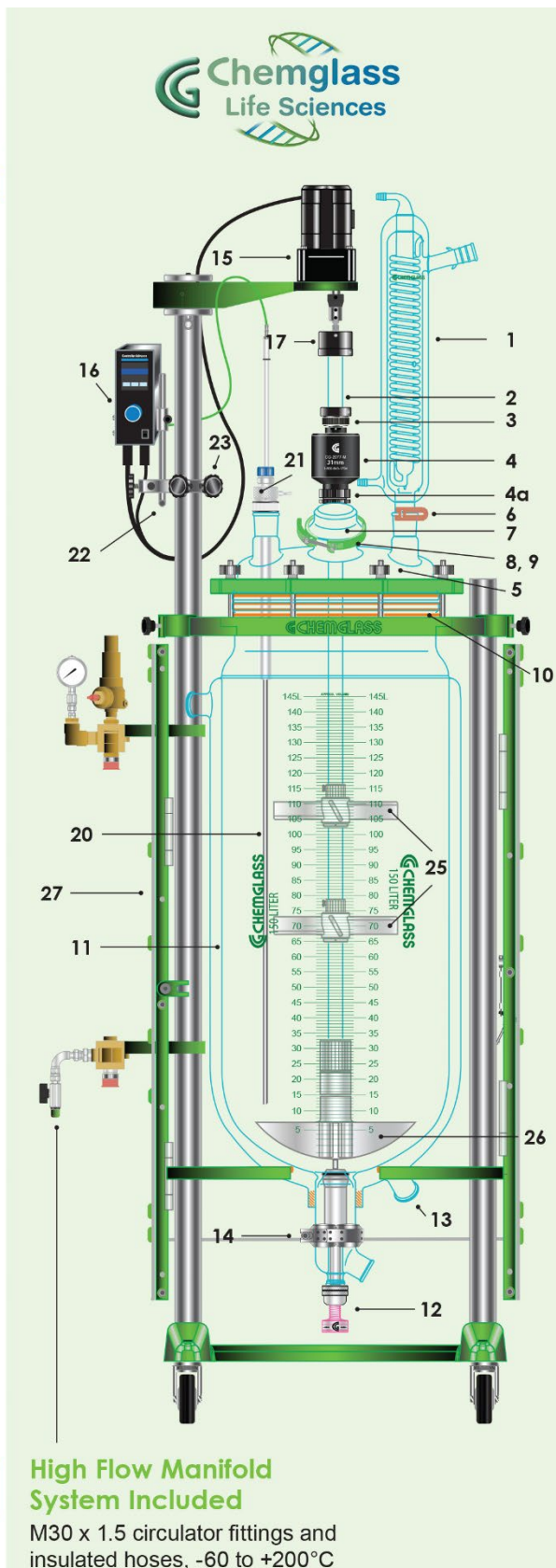

High Flow Manifold System Included

M30 x 1.5 circulator fittings and insulated hoses, -60 to +200°C

CUSTOM REACTOR & ENGINEERING SOLUTIONS

CUSTOM REACTOR AND ENGINEERING SOLUTIONS

Chemglass Life Sciences has the experience and expertise to design and fabricate custom engineered solutions for any application

- Custom Reactor Systems
- Large Scale Round Bottom Flask Systems
- Stationary and Tilting Stands and Supports
- Custom Carts and Frames for columns, flasks, feed vessels and receiver vessels
- Custom Filter or Mixing systems
- Accessories that interface to our reactor systems: Example: bulk powder addition bags

For more information contact our Technical Service Department at 1-800-843-1794 or email technical-service@cglifesciences.com



Complete Assembly Instructions

The jacketed process reactor, the fully assembled reactor head, stirrer shaft & agitators, PTFE stirrer bearing, temperature probe & adapter, high flow manifold blocks, and safety shields are shipped assembled on the support frame. All joints must be properly greased to avoid "freezing" and improve vacuum. PTFE sleeves and keck clips are available separately.

1. Carefully lower the reaction vessel into the support frame and rest the bottom of flange on the red silicone tubing. Slide front reaction vessel plate tight against the reactor and tighten the plate via the four Allen screws (Figure A).
2. Raise lower support ring so the bottom of the vessel is supported by the silicone rubber ring. Note: The reactor upper support floats to allow for vessel expansion.
3. Attach the zero dead space drain valve to reaction vessel via 3" beaded pipe coupling. Tighten coupling to specified torque setting.
4. Attach the high flow manifold system to support frame, as described above, and then attach the S.S. beaded pipe end of hose to inlet/outlet of reaction vessel.
5. Place the Perfluoroelastomer gasket on the flange of the reaction vessel.
6. Assemble the stirrer shaft and agitators, and lower into the reaction vessel.
7. While lowering the reaction vessel lid onto the vessel, carefully insert the end of the stirrer shaft through the center neck of the lid. **PLEASE NOTE: THE PTFE STIRRER BEARING IS NOT INSERTED AT THIS TIME.**
8. Slide the PTFE stirrer bearing over the end of the stirrer shaft and "press" into the center neck, sealing the o-ring.
9. Position the powder fill port towards the front of the reactor.
10. Secure the vessel and lid together with the clamp ring, making sure the entire gasket is seated evenly on the flange. Tighten the wing nuts in a star-like pattern (Figure B). Work your way around the entire clamp until you have repeated this 3-4 times and all the wing nuts are tight. **DO NOT OVER TIGHTEN.**
11. Attach the 3/8 HP electric stirrer motor to the upper universal motor mount arm via four socket head cap screws. Screws are shipped installed on the motor.
12. Attach the stirrer shaft coupling to the electric stirrer motor shaft.
13. Insert the end of the stirrer shaft into the coupling and tighten the collar with an Allen wrench. Check the vertical alignment of the reactor and adjust if necessary.
14. Tighten the black compression nut on the PTFE stirrer bearing, which compresses the bearing onto the stirring shaft.
15. Attach the motor controller/temperature monitor to the support frame via the large Kwik Klamp II and 1/2" OD 90° support rod.
16. Attach the control cord from the electric stirrer motor to the side of the controller. Make sure the speed control knob on the controller is turned completely off **BEFORE** turning the controller on. If using the air motor, attach the air source to the motor. The brass needle valve on the back of the air motor should be **CLOSED**.
17. Insert thermocouple through the thermocouple adapter and then insert the adapter into the desired side neck. Adjust the depth of the thermocouple by tightening the Chem-Thread at the top of the adapter. **PLEASE NOTE: CHECK TO SEE THAT THE THERMOCOUPLE DOES NOT COME INTO CONTACT WITH ANY OF THE AGITATORS BY MANUALLY TURNING THE STIRRER SHAFT.** Attach the thermocouple cord to the probe and then to the temperature monitor.
18. Attach condensers and any other peripheral glassware.

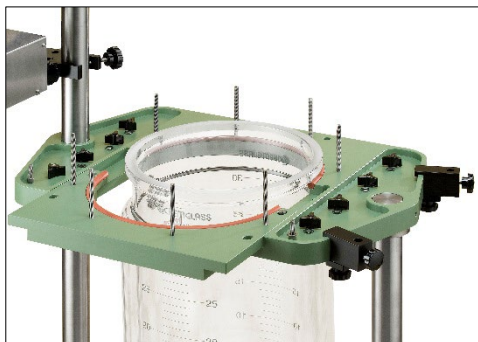

Figure A

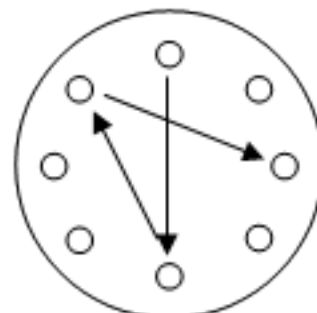

Figure B

Optional Components:



400mm 7-Neck Stainless Steel Lid



Air Operated Drain Valve



Huber Circulators



Mechanical Seal Stirrer Bearing



Powder Addition Funnel

CG-1978-P, CG-1979-P and CG-3498 Probes for Reactor Systems Installed in Hazardous/XP or ATEX environments.

Chemglass PT100 and thermocouple probes that will be used in a hazardous/explosion proof area must be used with a Zener barrier.

Zener barriers are used in control and instrumentation systems for the process of standardized signals, such as 20 mA or 10 V. Zener barriers contain intrinsically safe circuits that are to be used to drive intrinsically safe field devices with hazardous area. The manufacturer's data sheets must be consulted. The relevant regulations and directives governing the intended application must be followed. Zener barriers must be installed in conformance with the National Electrical Code. Please check with your company/university.

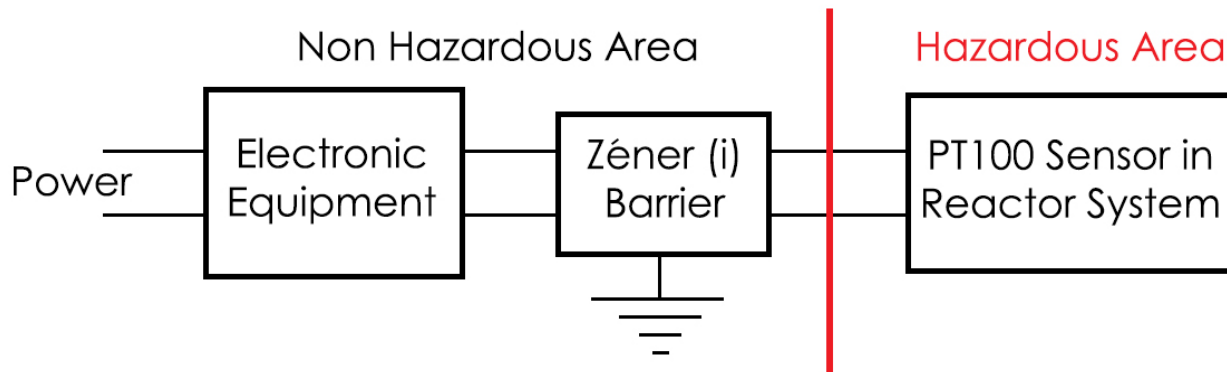

3800 North Mill Road, Vineland, NJ 08360
US & Canada Phone: (800) 843-1794 International: (856) 696-0014
US & Canada Fax: (800) 922-4361 International: (856) 696-9102