

## ASSEMBLY INSTRUCTIONS FOR 10L, 15L, & 20L UNJACKETED PROCESS REACTOR SYSTEMS

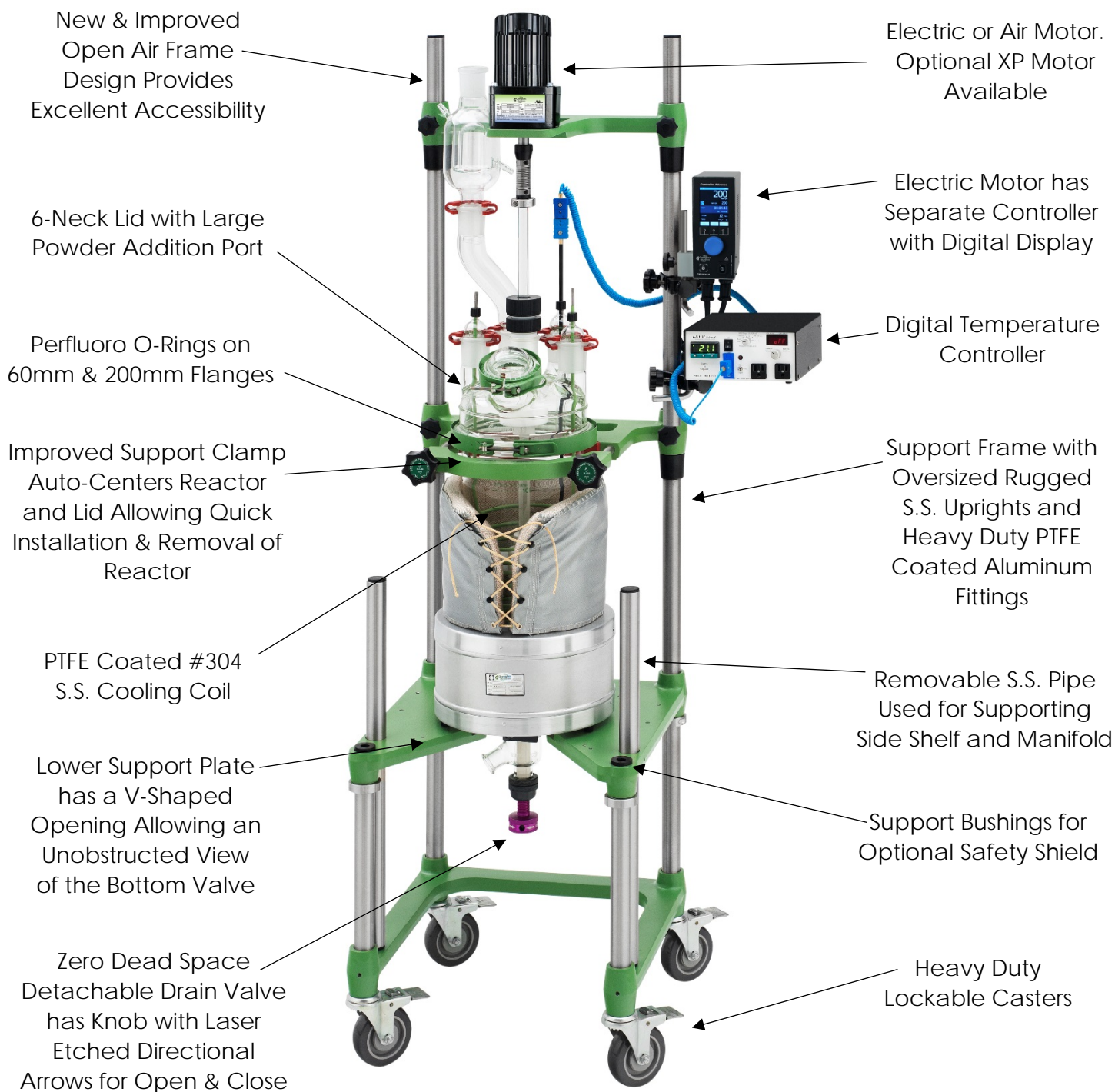

## Read Entire Assembly Instructions Before You Begin. Familiarize Yourself with All of the Parts, and Pay Close Attention to All Notes and Highlights.

Support frames are shipped via common carrier and require loading dock access with a fork lift or jack. If you do not have a loading dock, then a lift gate-equipped truck must be requested at the time of order.

For your convenience, the unjacketed process reactor, the fully assembled reactor head, stirrer shaft & agitators, Tru-Stir™ stirrer shaft coupling, flake catching cup, PTFE stirrer bearing, temperature probe & adapter, and motor are shipped assembled on the support frame. PTFE sleeves and keck clips are available separately.

Unpack all of the parts and check against the packing slip to make sure you have received all necessary components. If possible, keep some of the packaging materials from the wood crates in case you need to return items for repair or replacement.

### Crate # 1:

- Unpack the support frame with reactor and components by removing the plastic electrical ties that hold the reactor in place and remove the cardboard/foam packing from around the reactor. Re-tighten all of the Allen screws with the supplied wrenches, adjust all black knobs and tighten torque knobs. The red silicone pad should be touching the straight section of the glass below the reactor flange. **CHECK ALL ALLEN SCREWS BEFORE PROCEEDING; SCREWS CAN LOOSEN DURING SHIPMENT.**
- Attach the Tru-Stir™ stirrer shaft coupling to the 1/4 HP electric stirrer motor.

### Crate # 2:

- Contains the condenser, zero dead space drain valve, temperature monitor, motor controller, and other miscellaneous parts.

Move the reactor assembly and parts near the hood or area where the reactor will be used, but allow enough space to move freely around the support frame. During setup, preparation, and process, it is best to keep the wheels in their locked position by stepping down on the tab.



**\*PLEASE NOTE:** Torque knobs should be checked periodically to ensure the torque function has not been adversely affected by corrosion.

## Overhead Stirrer Motor



Air Motor



1/4 HP Vertical Motor



1/4 HP Horizontal Motor



Explosion Proof (XP) Motor

The motor is installed on the support frame when shipped. Use the following instructions should you need to remove or adjust these components.

### Components Needed for Overhead Stirrer Motor:

1ea	CG-2033-B-25	1/4 HP Vertical Electric Stirrer Motor
1ea	CG-2025-20	Air Motor* (Optional)
1ea	CG-2033-V-75	Digital Electric Stirrer Motor Controller (Only Supplied with 1/4 HP Electric Stirrer Motor)
1ea	CG-2044	Tru-Stir™ Stirrer Shaft Coupling
1ea	CG-9253-10	Small Kwik Klamp II
1ea	CG-3498-03	90° Support Rod

1. The support frame has a universal motor mount. It can be used with an (vertical or horizontal) electric, air, or optional explosion proof (XP) motor. The mount automatically centers the motor directly above the reactor.
2. The 1/4 HP electric motor is shipped attached to the support frame via four socket head cap screws.
3. When using the 1/4 HP electric motor, the digital controller, with mounting bracket on back panel, needs to be mounted on the S.S. upright. Use the small Kwik Klamp II and the 90° S.S. support rod to mount the controller to the support frame. Tighten all knobs securely.

\*The Air Motor requires the air supply be filtered and a lubricator be installed between the air source and motor. Filter-Regulator-Lubricator (CG-2025-10) is available separately.

## Stirrer Shaft and Agitator Assembly

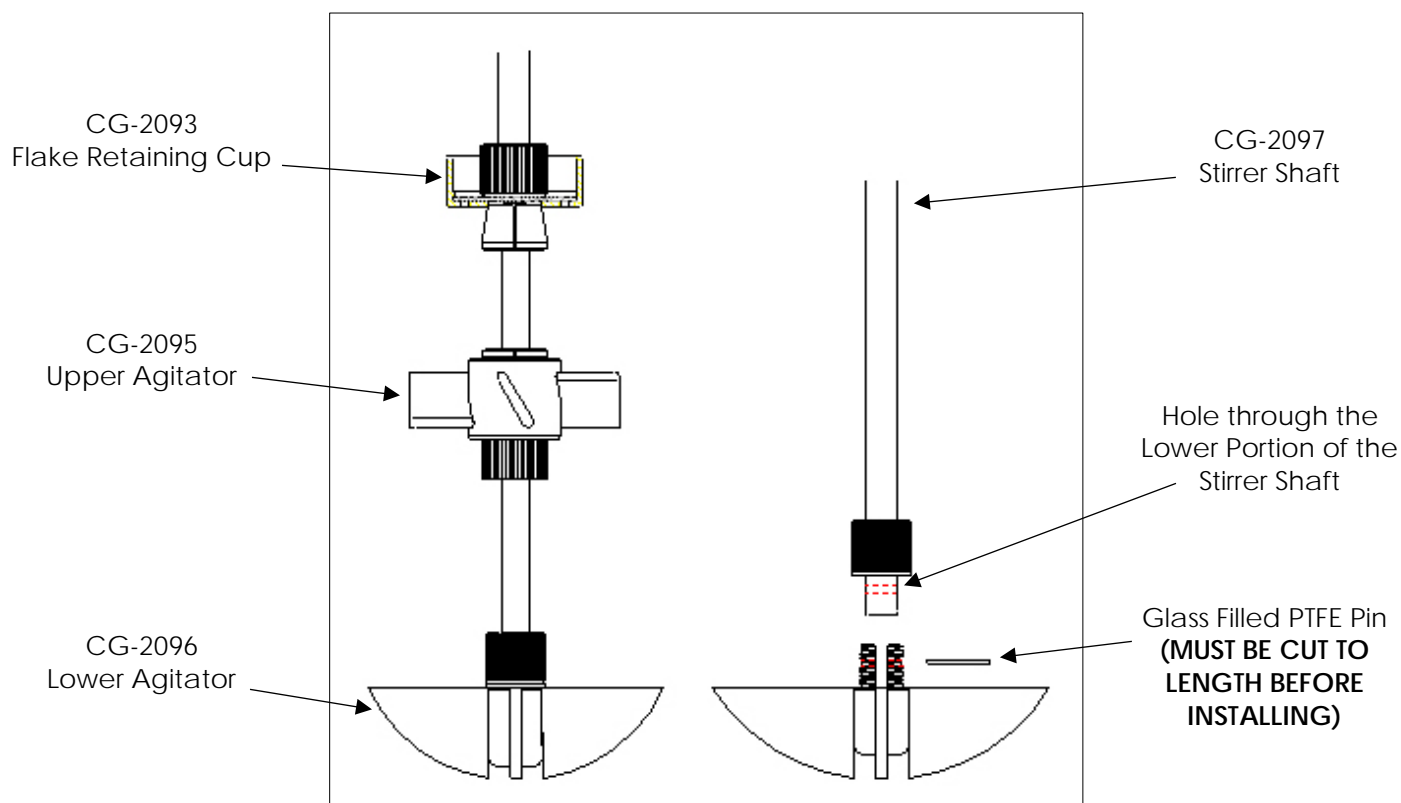

The stirrer shaft and agitators are assembled and installed when shipped. Use the following instructions should you need to remove or adjust these components.

### Components Needed for Stirrer Shaft and Agitator Assembly:

- 1ea CG-2097 Stirrer Shaft
- 1ea CG-2093 Flake Retaining Cup
- 1ea CG-2095 Upper PTFE Agitator
- 1ea CG-2096 Lower High Viscosity PTFE Agitator

1. The lower agitator assembly (CG-2096) is placed on the end of the stirrer shaft aligning the hole on the stirrer shaft with the holes in the PTFE hub. The sand blasted portion is the lower end of the stirrer shaft. Insert the glass filled PTFE pin. The pin must be cut to 24mm long before installing. Tighten the compression fitting. PLEASE NOTE: THE PTFE PIN MUST BE INSTALLED BEFORE USING.
2. The upper agitator assembly (CG-2095) slides over the end of the shaft. The height from the bottom will depend on the total volume you intend to run in the reactor.
3. Once you have the upper agitator in place, tighten the compression fitting as tight as possible (by hand). For use at higher temperatures, Chemglass recommends heating the upper agitator hub with a heat gun and then retightening. Then tighten the set screw on the flat of the stirrer shaft using a screwdriver. This will minimize the possibility of the agitator falling or slipping at higher temperatures.
4. The PTFE flake retaining cup (CG-2093) slides over the top of the stirrer shaft and is positioned approximately 18 inches from the bottom of the lower agitator assembly (CG-2096). For the cup to work effectively, the final position will have to be adjusted so that it is not less than 1 inch away from the bottom of the PTFE stirrer bearing.

## Zero Dead Space Drain Valve



**WARNING: PLEASE NOTICE TEMPERATURE LIMITATIONS ON O-RINGS LISTED BELOW BEFORE USING THIS VALVE. PLEASE USE THE CORRECT O-RING FOR THE TIP BASE ON YOUR APPLICATION TEMPERATURE.**

<u>O-Ring Material</u>	<u>Color</u>	<u>Temp Range (°C)</u>
Perfluoro	Black or White	-7 to 230
FEP-Silicone	Orange	-62 to 205

### Components Needed for Zero Dead Space Drain Valve:

- 1ea CG-1968-GL-040 Zero Dead Space Drain Valve
- 1ea CG-1968-67 2" Beaded Pipe Coupling

1. Loosen the nut on the 2" beaded pipe coupling (CG-1968-67). Wet the PTFE/Viton liner inside the coupling and attach on side to the 2" beaded pipe drain valve seat on the reactor.
2. Attach the drain valve assembly (CG-1968-GL-040) to the other side of the coupling. **PLEASE NOTE: PLUG MUST BE IN THE OPEN POSITION. AFTER ASSEMBLY, BE SURE THE PLUG IS IN THE CLOSED POSITION PRIOR TO FILLING THE REACTOR.**
3. Tighten the 2" beaded pipe coupling to 60in-lbs using a torque wrench.

### BEFORE YOU START:

The reactor is now ready for use. Before filling the reactor, make sure the zero dead space drain valve is in the closed position. Once setup is complete, the reactor can be moved into position and connected to the circulator. Keep the wheels locked for added safety.

Chemglass presumes some knowledge of this type of equipment on the part of the end user. Properties such as mechanical strength of glass, thermal stress introduced to the reactor from exothermic reactions, allowable temperature differentials, pressure and vacuum must all be considered with extreme caution.

If you have any questions, please contact our technical service department at (800) 843-1794 or [technical-service@cglifesciences.com](mailto:technical-service@cglifesciences.com).

### Optional Components:



Safety Shield



Mechanical Seal Stir Bearing

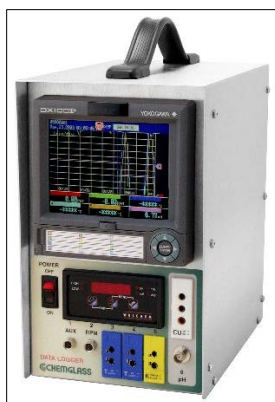

Data Logger



Powder Addition Funnel



Distillation Side Support Shelf

## Complete Assembly Instructions

The unjacketed process reactor, the fully assembled reactor head, stirrer shaft & agitators, Tru-Stir™ stirrer shaft coupling, flake retaining cup, PTFE stirrer bearing, temperature probe & adapter, and motor are shipped assembled on the support frame. Use the following instructions should you need to remove or adjust these components.

1. Attach the zero dead space drain valve (CG-1968-GL-040) to the reaction vessel via the 2" beaded pipe coupling (CG-1968). Tighten the coupling to the specified torque setting.
2. Carefully place the reaction vessel in the support frame on top of the supplied PTFE "V" cut support ring. Replace the front reaction vessel clamp and tighten the torque knobs evenly until you hear a "click".
3. Place the 200mm Perfluoro o-ring into the groove of the reaction vessel flange.
4. Assemble the stirrer shaft, agitators, and PTFE flake retaining cup and lower into the reaction vessel.
5. While lowering the reaction vessel lid onto the vessel, carefully insert the end of the stirrer shaft through the 45/50 center neck of the lid. **PLEASE NOTE: THE PTFE STIRRER BEARING IS NOT INSERTED IN THE HEAD AT THIS TIME.**
6. Dismantle then slide the PTFE stirrer bearing over the end of the stirrer shaft and "press" into the center neck, sealing the o-ring.
7. Position the powder fill port towards the front of the reactor.
8. Secure the vessel and lid together with the quick release PTFE coated clamp, making sure the entire o-ring is seated in the groove. Adjust the threaded bolt to improve the seal around the flange.
9. Attach the Tru-Stir stirrer shaft coupling to the 1/4 HP electric stirrer motor shaft. Then attach the motor to the support frame via the supplied four socket head cap screws.
10. Insert the end of the stirrer shaft into the stirrer shaft coupling and tighten the collar with an Allen wrench. Check the vertical alignment of the reactor and adjust if necessary.
11. Tighten the black compression nut on the PTFE stirrer bearing, which compresses the bearing onto the stirrer shaft.
12. Attach the electric stirrer motor controller and the digital temperature monitor to the support frame via the small Kwik Klamp II and 1/2" OD 90° S.S. support rod.
13. Attach the control cord from the electric stirrer motor to the side panel of the controller. Make sure that the speed control knob on the controller is turned completely off BEFORE turning the controller on. If using the air motor, attach air source to the motor. The brass needle valve on the back of the air motor should be CLOSED.
14. Loosen compression nut and insert the thermocouple thru the thermocouple adapter and then insert the adapter into the desired side neck. Adjust the depth of the thermocouple by tightening the Chem-Thread at the top of the adapter. **PLEASE NOTE: CHECK TO SEE THAT THE THERMOCOUPLE DOES NOT COME INTO CONTACT WITH EITHER OF THE AGITATORS BY MANUALLY TURNING THE STIRRER SHAFT.** Attach the thermocouple cord to the probe then to the temperature monitor.
15. Place the digital temperature controller on the side stand and plug in heating jacket, lower heating mantle and thermocouple.
16. Attach the condenser and any other peripheral glassware.

# UNJACKETED REACTORS, 10L

## 10L PROCESS REACTOR, CYLINDRICAL, UNJACKETED, ELECTRIC OR AIR MOTOR

Complete reactor system on our NEW open air, auto-center stand. Supplied with the components listed below and numbered on the schematic drawing. Optional items are listed on the following pages. **PLEASE NOTE: REACTOR STAND OVERALL HEIGHT WITH MOTOR AND CLEARANCE BELOW VALVE, ARE CALCULATED FOR ALL CHEMGLASS STIRRER BEARINGS, INCLUDING THE CG-2077-M MECHANICAL SEAL STIR BEARING.**

### 10L COMPLETE PROCESS REACTORS:

Part Number	Description	Motor Type	Approx. Overall Height W/ Motor (in)	Clearance Below Valve (in)
CG-1967-610	10L Process Reactor, Complete	Electric	70.1	15.3
CG-1966-610	10L Process Reactor, Complete	Air	67.0	15.3

### Standard Components Supplied With Complete Process Reactors:

No.	Part No.	Description
1	CG-1217-25	Condenser, 45/50
2	CG-1033-45	Offset Adapter, 45/50
3	CG-2097-10	19mm Stirrer Shaft, 30-5/8" OAL
4	CG-2077-H-05	19mm PTFE Stir Bearing
5	CG-149-01	60mm Glass Cap
6	CG-141-T-11	60mm S.S. Clamp, PTFE Coated
7	CG-147-80	60mm Perfluoro O-Ring
8	CG-147-84	200mm Perfluoro O-Ring
9	CG-10013-10	10L Heating Mantle, Fabric with Slit, 115V
10	CG-12012-10	10L Heating Mantle, Aluminum Housed, 115V
11	CG-1968-67	2" Beaded Pipe Coupling
12a	CG-2033-B-25	Electric Stir Motor, 1/4Hp, 500 RPM
12b	CG-2025-20	Air Motor, 3/8Hp
12c	CG-2025-10	Filter-Regulator-Lubricator (Air Motor Only)
13a	CG-2044-20	19mm Tru-Stir® Shaft Coupling, (Electric)
13b	CG-2044-16	19mm Tru-Stir® Shaft Coupling, (Air)
14	CG-3499-05	10ft Coiled Extension Cord, "T"
15	CG-2033-V-75	Controller, Motor, Time (Electric Only)
16	CG-3498-106	1/4" Diameter x 26" Long Thermocouple, "T"
17	CG-3205-91	Temperature Controller, "T"
18	CG-3498-03	1/2" OD Rod, 90° Bend (2)
19	CG-9253-10	Universal Kwik Mount Klamp (2)
20	CG-1042-E-10	Thermocouple Adapter, 45/50
21	CG-1946-C-10	6-Neck Lid, 200mm
22	CG-141-T-15	200mm S.S. Clamp, PTFE Coated
23	CG-2093-20	PTFE Flake Catching Cup
24	CG-1924-31	10L Unjacketed Reaction Vessel
25	CG-1966-07	10L S.S. PTFE Coated Cooling Coil
26	CG-2095-05	5" OD PTFE Agitator, 60° (2ea)
27	CG-1965-X-150	Auto-Center Support Frame, 66" OAH
28	CG-1968-GL-040	Zero Dead Space Drain Valve
--	CG-145-09	45/50 Keck Clips (PK10)
---	CG-1042-45	Adapter, 45/50, Coil (2ea)
---	CG-1963-B-10	Beam Torque Wrench
---	CG-1963-B-14	7/16" Deep Socket, 6 Point, 1/4" Drive

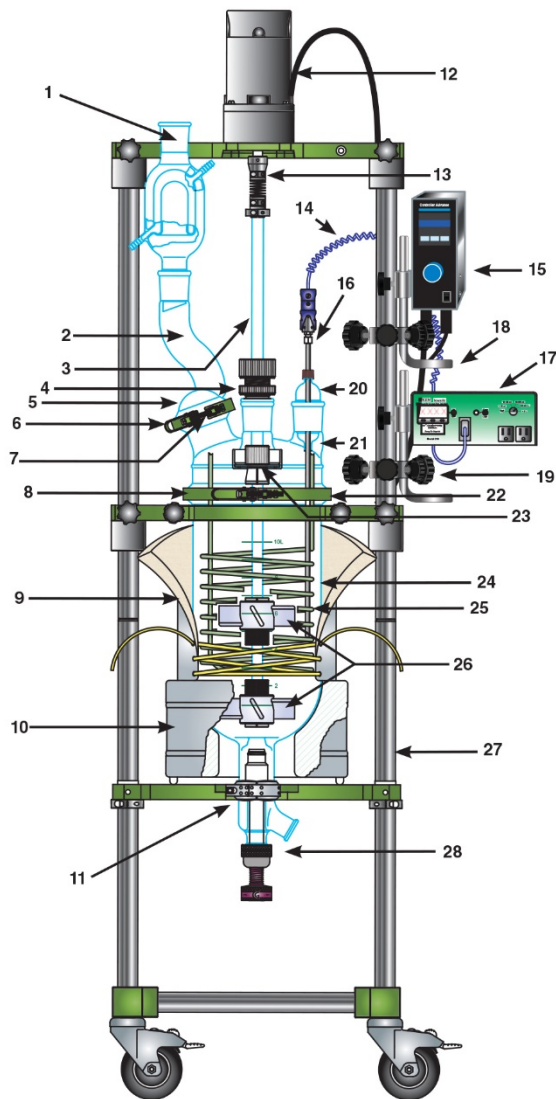

# UNJACKETED REACTORS, 15L

## 15L PROCESS REACTOR, CYLINDRICAL, UNJACKETED, ELECTRIC OR AIR MOTOR

Complete reactor system on our NEW open air, auto-center stand. Supplied with the components listed below and numbered on the schematic drawing. Optional items are listed on the following pages. **PLEASE NOTE: REACTOR STAND OVERALL HEIGHT WITH MOTOR AND CLEARANCE BELOW VALVE, ARE CALCULATED FOR ALL CHEMGLASS STIRRER BEARINGS, INCLUDING THE CG-2077-M MECHANICAL SEAL STIR BEARING.**

### 15L COMPLETE PROCESS REACTORS:

Part Number	Description	Motor Type	Approx. Overall Height W/ Motor (in)	Clearance Below Valve (in)
CG-1967-615	15L Process Reactor, Complete	Electric	70.1	15.3
CG-1966-615	15L Process Reactor, Complete	Air	67.0	15.3

### Standard Components Supplied With Complete Process Reactors:

No.	Part No.	Description
1	CG-1217-25	Condenser, 45/50
2	CG-1033-45	Offset Adapter, 45/50
3	CG-2097-10	19mm Stirrer Shaft, 30-5/8" OAL
4	CG-2077-H-05	19mm PTFE Stir Bearing
5	CG-149-01	60mm Glass Cap
6	CG-141-T-11	60mm S.S. Clamp, PTFE Coated
7	CG-147-80	60mm Perfluoro O-Ring
8	CG-147-84	200mm Perfluoro O-Ring
9	CG-10013-15	15L Heating Mantle, Fabric with Slit, 115V
10	CG-12012-15	15L Heating Mantle, Aluminum Housed, 115V
11	CG-1968-67	2" Beaded Pipe Coupling
12a	CG-2033-B-25	Electric Stir Motor, 1/4Hp, 500 RPM
12b	CG-2025-20	Air Motor, 3/8Hp
12c	CG-2025-10	Filter-Regulator-Lubricator (Air Motor Only)
13a	CG-2044-20	19mm Tru-Stir® Shaft Coupling, (Electric)
13b	CG-2044-16	19mm Tru-Stir® Shaft Coupling, (Air)
14	CG-3499-05	10ft Coiled Extension Cord, "T"
15	CG-2033-V-75	Controller, Motor, Time (Electric Only)
16	CG-3498-106	1/4" Diameter x 26" Long Thermocouple, "T"
17	CG-3205-91	Temperature Controller, "T"
18	CG-3498-03	1/2" OD Rod, 90° Bend (2)
19	CG-9253-10	Universal Kwik Mount Klamp (2)
20	CG-1042-E-10	Thermocouple Adapter, 45/50
21	CG-1946-C-10	6-Neck Lid, 200mm
22	CG-141-T-15	200mm S.S. Clamp, PTFE Coated
23	CG-2093-20	PTFE Flake Catching Cup
24	CG-1924-33	15L Unjacketed Reaction Vessel
25	CG-1966-17	15L S.S. PTFE Coated Cooling Coil
26	CG-2095-05	5" OD PTFE Agitator, 60° (2ea)
27	CG-1965-X-150	Auto-Center Support Frame, 66" OAH
28	CG-1968-GL-040	Zero Dead Space Drain Valve
--	CG-145-09	45/50 Keck Clips (PK10)
---	CG-1042-45	Adapter, 45/50, Coil (2ea)
---	CG-1963-B-10	Beam Torque Wrench
---	CG-1963-B-14	7/16" Deep Socket, 6 Point, 1/4" Drive

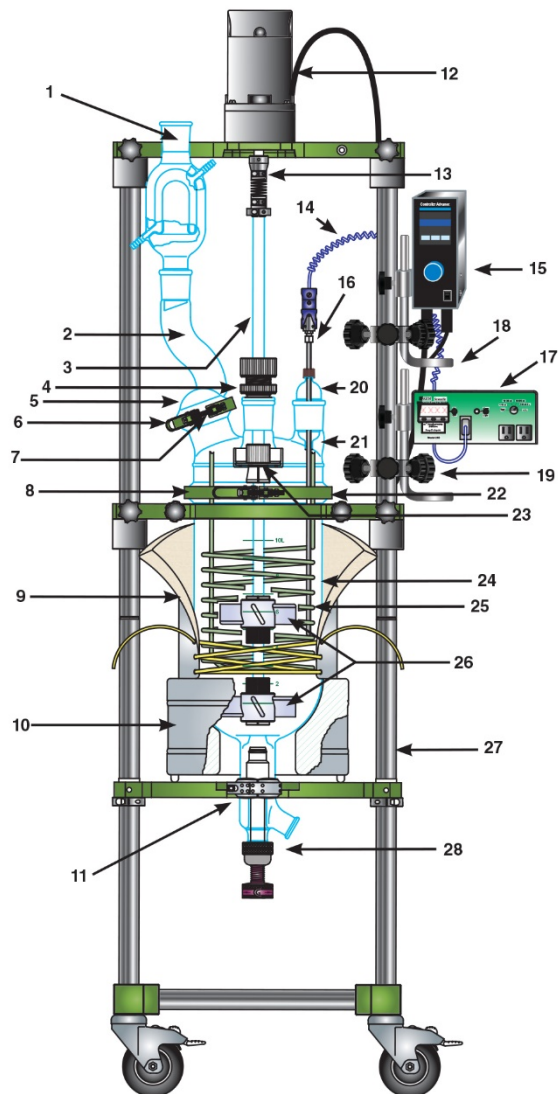



# UNJACKETED REACTORS, 20L

## 20L PROCESS REACTOR, CYLINDRICAL, UNJACKETED, ELECTRIC OR AIR MOTOR

Complete reactor system on our NEW open air, auto-center stand. Supplied with the components listed below and numbered on the schematic drawing. Optional items are listed on the following pages. **PLEASE NOTE: REACTOR STAND OVERALL HEIGHT WITH MOTOR AND CLEARANCE BELOW VALVE, ARE CALCULATED FOR ALL CHEMGLASS STIRRER BEARINGS, INCLUDING THE CG-2077-M MECHANICAL SEAL STIR BEARING.**

### 20L COMPLETE PROCESS REACTORS:

Part Number	Description	Motor Type	Approx. Overall Height W/ Motor (in)	Clearance Below Valve (in)
CG-1967-620	20L Process Reactor, Complete	Electric	70.1	15.3
CG-1966-620	20L Process Reactor, Complete	Air	67.0	15.3

### Standard Components Supplied With Complete Process Reactors:

No.	Part No.	Description
1	CG-1217-25	Condenser, 45/50
2	CG-1033-45	Offset Adapter, 45/50
3	CG-2097-12	19mm Stirrer Shaft, 34-5/8" OAL
4	CG-2077-H-05	19mm PTFE Stir Bearing
5	CG-149-01	60mm Glass Cap
6	CG-141-T-11	60mm S.S. Clamp, PTFE Coated
7	CG-147-80	60mm Perfluoro O-Ring
8	CG-147-84	200mm Perfluoro O-Ring
9	CG-10013-20	20L Heating Mantle, Fabric with Slit, 115V
10	CG-12012-20	20L Heating Mantle, Aluminum Housed, 115V
11	CG-1968-67	2" Beaded Pipe Coupling
12a	CG-2033-B-25	Electric Stir Motor, 1/4Hp, 500 RPM
12b	CG-2025-20	Air Motor, 3/8Hp
12c	CG-2025-10	Filter-Regulator-Lubricator (Air Motor Only)
13a	CG-2044-20	19mm Tru-Stir® Shaft Coupling, (Electric)
13b	CG-2044-16	19mm Tru-Stir® Shaft Coupling, (Air)
14	CG-3499-05	10ft Coiled Extension Cord, "T"
15	CG-2033-V-75	Controller, Motor, Time (Electric Only)
16	CG-3498-106	1/4" Diameter x 26" Long Thermocouple, "T"
17	CG-3205-91	Temperature Controller, "T"
18	CG-3498-03	1/2" OD Rod, 90° Bend (2)
19	CG-9253-10	Universal Kwik Mount Klamp (2)
20	CG-1042-E-10	Thermocouple Adapter, 45/50
21	CG-1946-C-10	6-Neck Lid, 200mm
22	CG-141-T-15	200mm S.S. Clamp, PTFE Coated
23	CG-2093-20	PTFE Flake Catching Cup
24	CG-1924-34	20L Unjacketed Reaction Vessel
25	CG-1966-07	20L S.S. PTFE Coated Cooling Coil
26	CG-2095-05	5" OD PTFE Agitator, 60° (2ea)
27	CG-1965-X-150	Auto-Center Support Frame, 66" OAH
28	CG-1968-GL-040	Zero Dead Space Drain Valve
--	CG-145-09	45/50 Keck Clips (PK10)
---	CG-1042-45	Adapter, 45/50, Coil (2ea)
---	CG-1963-B-10	Beam Torque Wrench
---	CG-1963-B-14	7/16" Deep Socket, 6 Point, 1/4" Drive

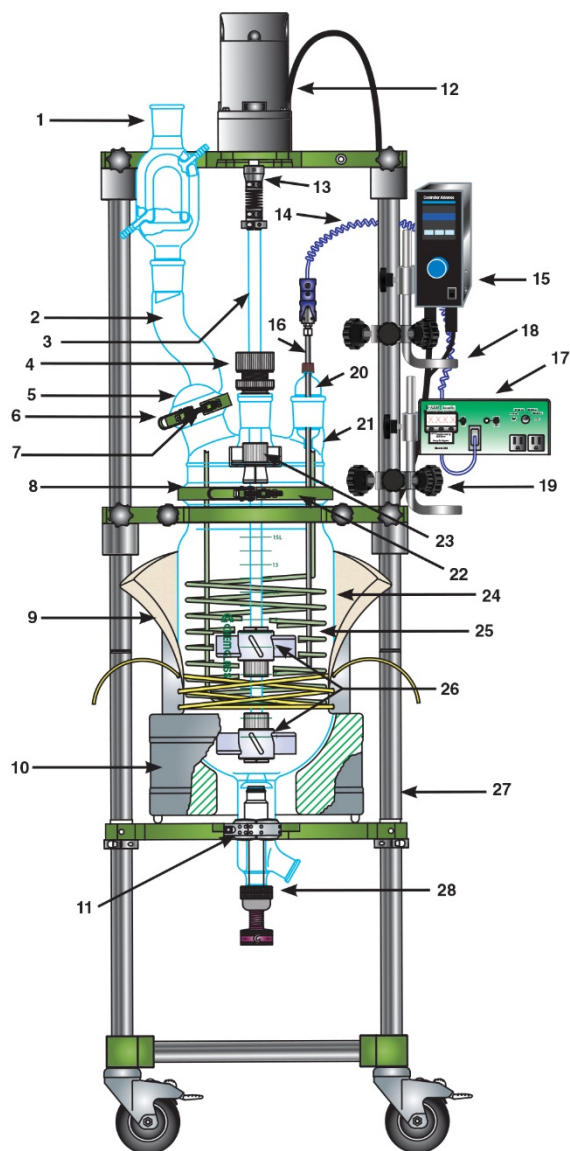

Optional Components:



Safety Shield



Mechanical Seal Stir Bearing



Side Support Shelf



Distillation Side Support Shelf



Powder Addition Funnel



Data Logger

CG-1978-P, CG-1979-P and CG-3498 Probes for Reactor Systems Installed in Hazardous/XP or ATEX environments.

Chemglass PT100 and thermocouple probes that will be used in a hazardous/explosion proof area must be used with a Zener barrier.

Zener barriers are used in control and instrumentation systems for the process of standardized signals, such as 20 mA or 10 V. Zener barriers contain intrinsically safe circuits that are to be used to drive intrinsically safe field devices with hazardous area. The manufacturer's data sheets must be consulted. The relevant regulations and directives governing the intended application must be followed. Zener barriers must be installed in conformance with the National Electrical Code. Please check with your company/university.

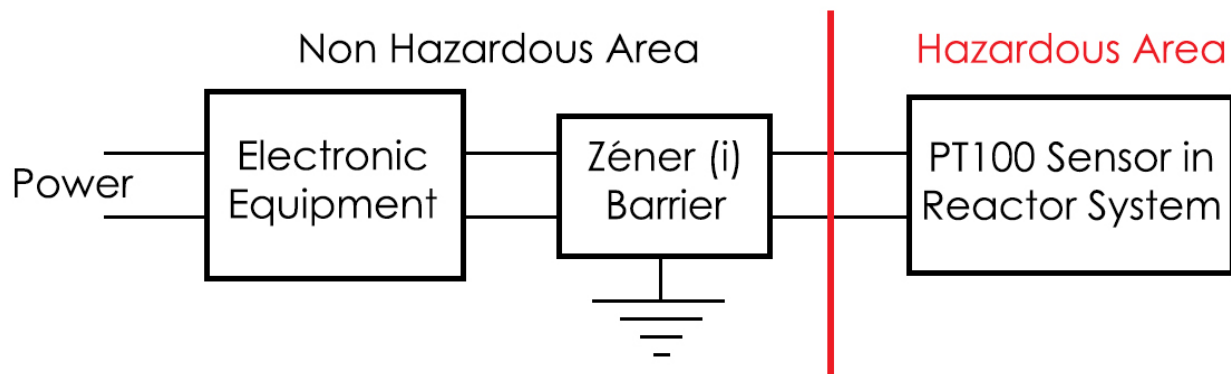

3800 North Mill Road, Vineland, NJ 08360  
US & Canada Phone: (800) 843-1794 International: (856) 696-0014  
US & Canada Fax: (800) 922-4361 International: (856) 696-9102

REV\_AUGUST\_2019