

ASSEMBLY INSTRUCTIONS FOR UNJACKETED FILTER REACTOR SYSTEMS

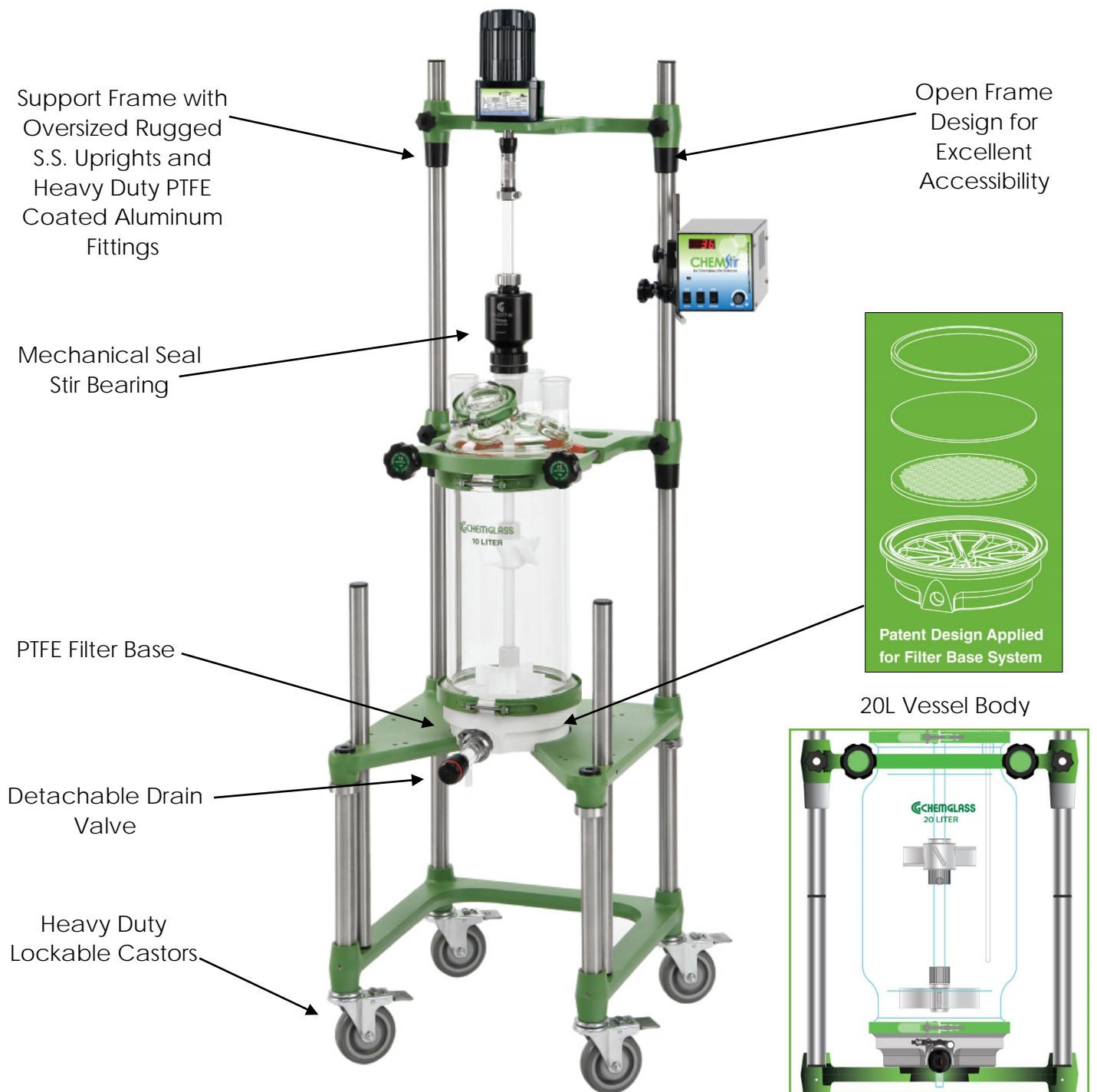

PLEASE NOTE: FILTER REACTORS ARE FOR VACUUM/GRAVITY FILTRATION USE ONLY.

Read Entire Assembly Instructions Before You Begin. Familiarize Yourself with All of the Parts, and Pay Close Attention to All Notes and Highlights.

Support frames are shipped via common carrier and require loading dock access with a fork lift or jack. If you do not have a loading dock, then a lift gate-equipped truck must be requested at the time of order.

For your convenience, the unjacketed process filter reactor, the fully assembled reactor head, stirrer shaft & agitators, Tru-Stir™ stirrer shaft coupling, PTFE stirrer bearing, temperature probe & adapter, and motor are shipped assembled on the support frame. PTFE sleeves and keck clips are available separately.

Unpack all of the parts and check against the packing slip to make sure you have received all necessary components. If possible, keep some of the packaging materials from the wood crates in case you need to return items for repair or replacement.

Crate # 1:

- Unpack the support frame with reactor and components by removing the plastic electrical ties that hold the reactor in place and remove the cardboard/foam packing from around the reactor. Re-tighten all of the Allen screws with the supplied wrenches, adjust all black knobs and tighten torque knobs. The red silicone pad should be touching the straight section of the glass below the reactor flange. **CHECK ALL ALLEN SCREWS BEFORE PROCEEDING; SCREWS CAN LOOSEN DURING SHIPMENT.**
- Attach the Tru-Stir™ stirrer shaft coupling to the 1/4 HP electric stirrer motor.

Crate # 2:

- Contains the condenser, 0-14mm drain valve, temperature monitor, motor controller, and other miscellaneous parts.

Move the reactor assembly and parts near the hood or area where the reactor will be used, but allow enough space to move freely around the support frame. During setup, preparation, and process, it is best to keep the wheels in their locked position by stepping down on the tab.

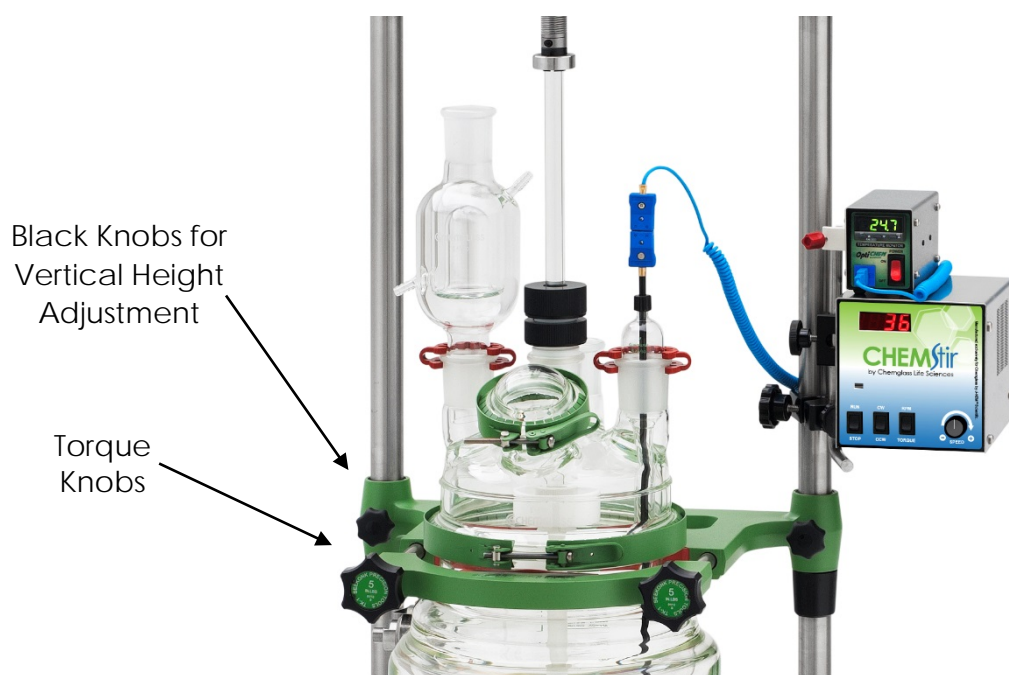

***PLEASE NOTE:**
Torque knobs should be checked periodically to ensure the torque function has not been adversely affected by corrosion.

Overhead Stirrer Motor



Air Motor



1/4 HP Vertical Motor



1/4 HP Horizontal Motor



Explosion Proof (XP) Motor

The motor is installed on the support frame when shipped. Use the following instructions should you need to remove or adjust these components.

Components Needed for Overhead Stirrer Motor:

1ea	CG-2033-B-25	1/4 HP Vertical Electric Stirrer Motor
1ea	CG-2025-20	Air Motor* (Optional)
1ea	CG-2033-B-50	Digital Electric Stirrer Motor Controller (Only Supplied with 1/4 HP Electric Stirrer Motor)
1ea	CG-2044	Tru-Stir™ Stirrer Shaft Coupling
1ea	CG-9253-10	Small Kwik Klamp II
1ea	CG-3498-03	90° Support Rod

1. The support frame has a universal motor mount. It can be used with an (vertical or horizontal) electric, air, or optional explosion proof (XP) motor. The mount automatically centers the motor directly above the reactor.
2. The 1/4 HP electric motor is shipped attached to the support frame via four socket head cap screws.
3. When using the 1/4 HP electric motor, the digital controller, with mounting bracket on back panel, needs to be mounted on the S.S. upright. Use the small Kwik Klamp II and the 90° S.S. support rod to mount the controller to the support frame. Tighten all knobs securely.

*The Air Motor requires the air supply be filtered and a lubricator be installed between the air source and motor. Filter-Regulator-Lubricator (CG-2025-10) is available separately.

Stirrer Shaft and Agitator Assembly

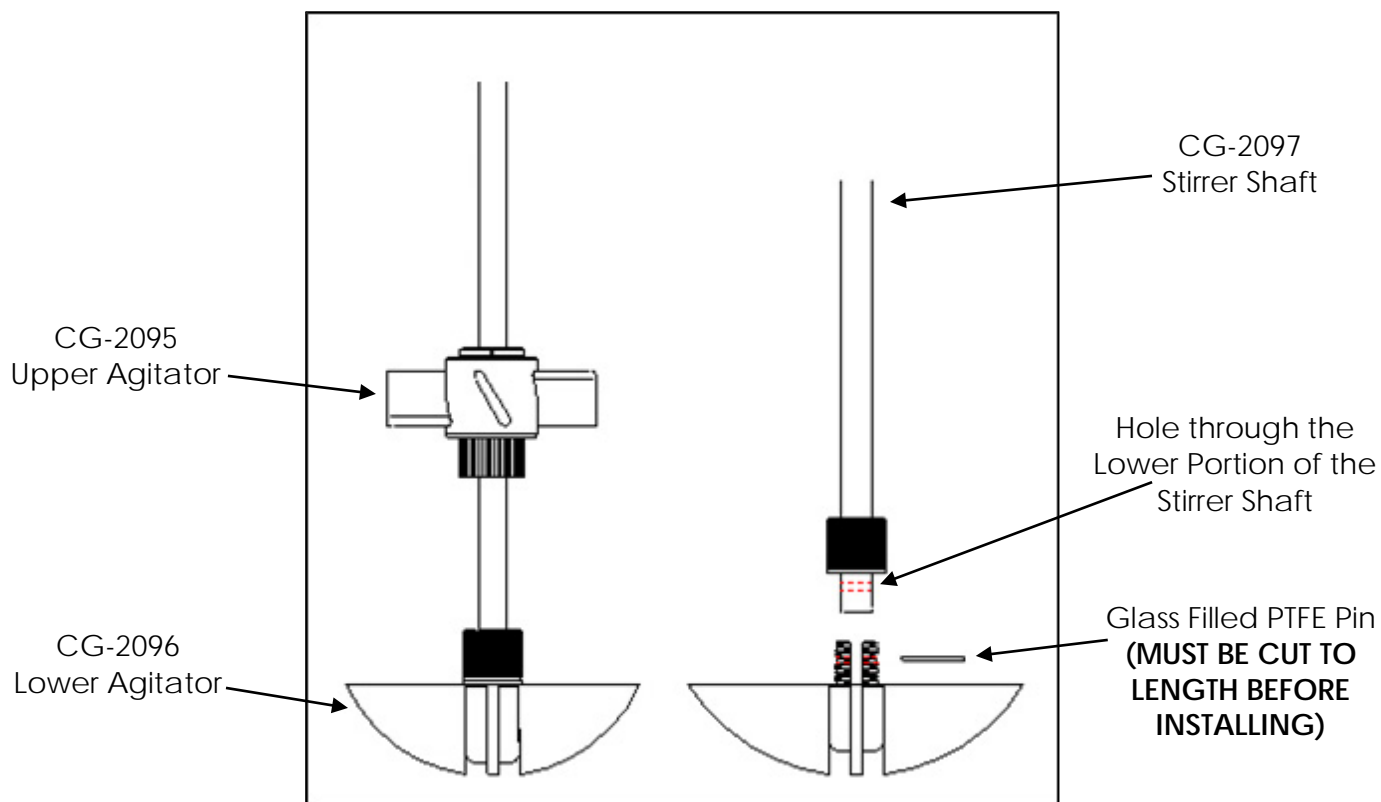

The stirrer shaft and agitators are assembled and installed when shipped. Use the following instructions should you need to remove or adjust these components.

Components Needed for Stirrer Shaft and Agitator Assembly:

- 1ea CG-2097 Stirrer Shaft
- 1ea CG-2093 Flake Retaining Cup
- 1ea CG-2095 Upper PTFE Agitator
- 1ea CG-2096 Lower High Viscosity PTFE Agitator

1. The lower agitator assembly (CG-2096) is placed on the end of the stirrer shaft aligning the hole on the stirrer shaft with the holes in the PTFE hub. The sand blasted portion is the lower end of the stirrer shaft. Insert the glass filled PTFE pin. The pin must be cut to 24mm long before installing. Tighten the compression fitting. PLEASE NOTE: THE PTFE PIN MUST BE INSTALLED BEFORE USING.
2. The upper agitator assembly (CG-2095) slides over the end of the shaft. The height from the bottom will depend on the total volume you intend to run in the reactor.
3. Once you have the upper agitator in place, tighten the compression fitting as tight as possible (by hand). For use at higher temperatures, Chemglass recommends heating the upper agitator hub with a heat gun and then retightening. Then tighten the set screw on the flat of the stirrer shaft using a screwdriver. This will minimize the possibility of the agitator falling or slipping at higher temperatures.
4. The PTFE flake retaining cup (CG-2093) slides over the top of the stirrer shaft and is positioned approximately 18 inches from the bottom of the lower agitator assembly (CG-2096). For the cup to work effectively, the final position will have to be adjusted so that it is not less than 1 inch away from the bottom of the PTFE stirrer bearing.

Filter Base System

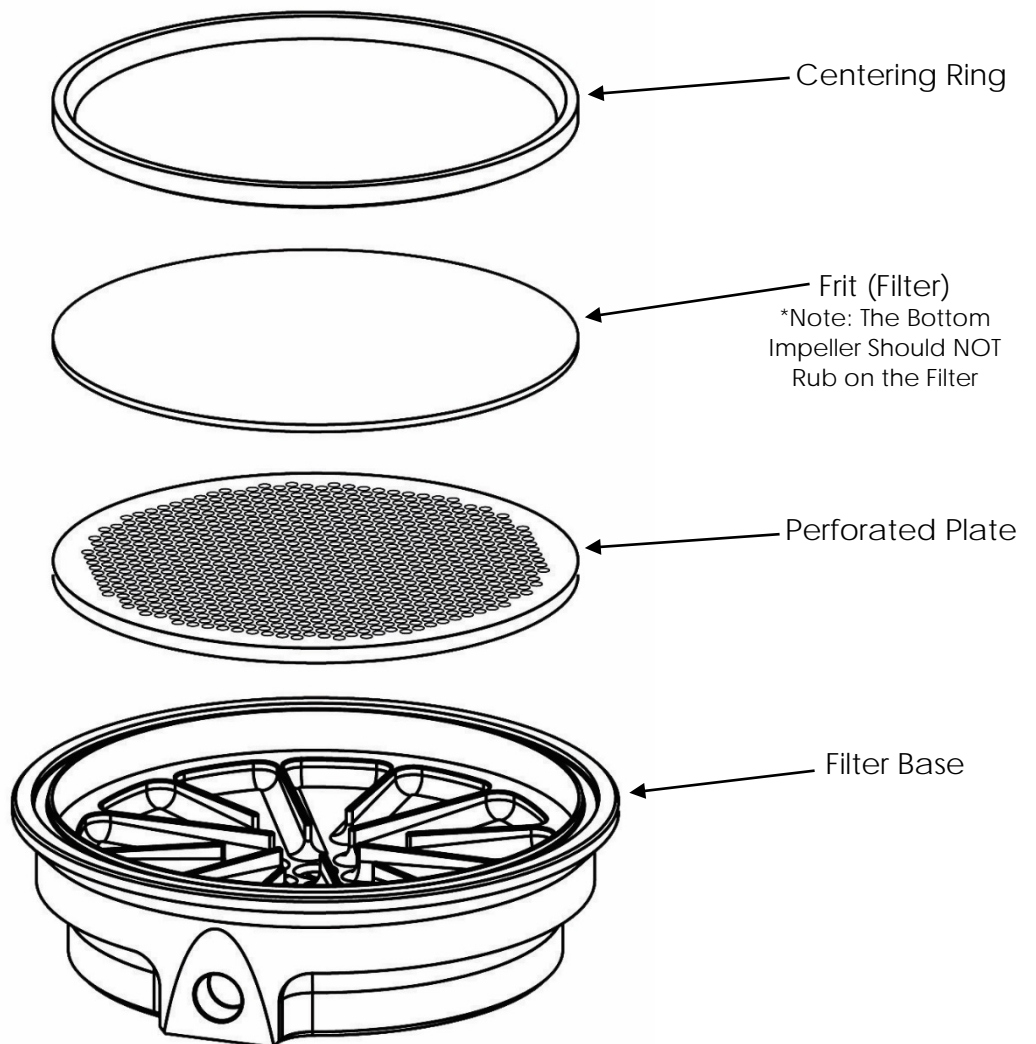

1. Place the o-ring in the beveled edge of the filter base.
2. Place the perforated plate in the filter base, beveled edge facing up.
3. Place the frit (filter) on top of the perforated plate.
4. Fix the centering ring on top of the frit and make sure it is pushed down on all edges evenly.
5. Wrap the lower outlet adapters with NPT end with PTFE tape. Thread the adapter into the filter base until it becomes snug. **DO NOT OVER TIGHTEN.**
6. Attach the beaded pipe coupling to the lower outlet drain and the CG-1959-A-01 0-14mm drain valve. Torque the beaded pipe coupling to 35in-lbs using a torque wrench.

BEFORE YOU START:

The reactor is now ready for use. Before filling the reactor, make sure the 0-14mm drain valve is in the closed position. Once setup is complete, the reactor can be moved into position and connected to the circulator. Keep the wheels locked for added safety.

Chemglass presumes some knowledge of this type of equipment on the part of the end user. Properties such as mechanical strength of glass, thermal stress introduced to the reactor from exothermic reactions, allowable temperature differentials, pressure and vacuum must all be considered with extreme caution.

If you have any questions, please contact our technical service department at (800) 843-1794 or technical-service@cglifesciences.com.

Complete Assembly Instructions

The unjacketed process filter reactor, the fully assembled reactor head, stirrer shaft & agitators, Tru-Stir™ stirrer shaft coupling, PTFE stirrer bearing, temperature probe & adapter, and motor are shipped assembled on the support frame. Use the following instructions should you need to remove or adjust these components.

1. Remove torque knobs from reactor support clamp and remove PTFE coated support clamp.
2. Please refer to filter base assembly then place filter base in the bottom of the reactor stand, positioning detachable drain valve toward the front of the stand.
3. Carefully place the reaction vessel on the filter base and line up with the vessel. Replace the front reaction vessel clamp and tighten the torque knobs evenly until you hear a "click".
4. Secure the vessel and filter base together with the CG-141-T quick release PTFE coated clamp, making sure that the entire o-ring is seated in the groove. Adjust the threaded bolt to improve the seal around the flange.
5. Place the 200mm Perfluoro o-ring into the groove of the top reaction vessel flange.
6. Assemble the stirrer shaft and agitators and lower into the reaction vessel.
7. While lowering the reaction vessel lid onto the vessel, carefully insert the end of the stirrer shaft through the 45/50 center neck of the lid. **PLEASE NOTE: THE MECHANICAL SEAL STIRRER BEARING IS NOT INSERTED IN THE HEAD AT THIS TIME.**
8. Dismantle then slide the mechanical seal stirrer bearing over the end of the stirrer shaft and "press" into the center neck, sealing the o-ring.
9. Position the powder fill port towards the front of the reactor.
10. Secure the vessel and lid together with the quick release PTFE coated clamp, making sure the entire o-ring is seated in the groove. Adjust the threaded bolt to improve the seal around the flange.
11. Attach the Tru-Stir stirrer shaft coupling to the 1/4 HP electric stirrer motor shaft. Then attach the motor to the support frame via the supplied four socket head cap screws.
12. Insert the end of the stirrer shaft into the stirrer shaft coupling and tighten the collar with an Allen wrench. Check the vertical alignment of the reactor and adjust if necessary.
13. Tighten the aluminum nut on the mechanical seal stirrer bearing, which compresses the bearing onto the stirrer shaft.
14. Attach the electric stirrer motor controller and the digital temperature monitor to the support frame via the small Kwik Klamp II and 1/2" OD 90°S.S. support rod.
15. Attach the control cord from the electric stirrer motor to the rear panel of the controller. Make sure that the speed control knob on the controller is turned completely off BEFORE turning the controller on. If using the air motor, attach air source to the motor. The brass needle valve on the back of the air motor should be CLOSED.
16. Loosen compression nut and insert the thermocouple thru the thermocouple adapter and then insert the adapter into the desired side neck. Adjust the depth of the thermocouple by tightening the Chem-Thread at the top of the adapter. **PLEASE NOTE: CHECK TO SEE THAT THE THERMOCOUPLE DOES NOT COME INTO CONTACT WITH EITHER OF THE AGITATORS BY MANUALLY TURNING THE STIRRER SHAFT.** Attach the thermocouple cord to the probe then to the temperature monitor.
17. Attach the condenser and any other peripheral glassware.

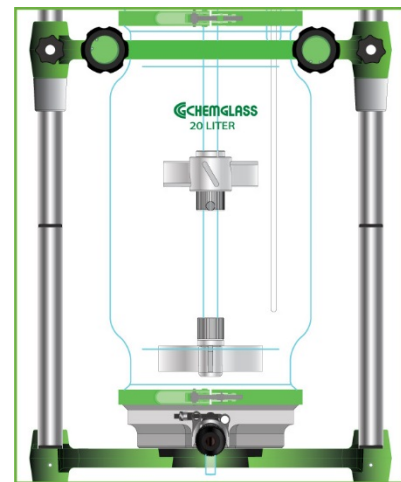

NOTE: THE BOTTOM IMPELLER SHOULD NOT BE RUBBING ON THE FILTER

REACTORS, FILTER, UNJACKETED

PROCESS FILTER REACTOR, CYLINDRICAL, UNJACKETED, ELECTRIC OR AIR MOTOR

Our unjacketed filter reactors can be used for single or multi-step reactions and filtrations in the same vessel, production and process scale peptide synthesis. Filter base eliminates material transfers and significantly reduces losses. Complete reactor system on our NEW open air, auto-center stand. Supplied with the components listed and numbered on the schematic drawing.

10L COMPLETE UNJACKETED FILTER REACTORS:

Part Number	Description	Motor Type	Overall Height W/ Motor (in)	Clearance Below Valve (in)
CG-1959-F810	10L Process Filter Reactor, Complete	Electric	72	19.4
CG-1958-F811	10L Process Filter Reactor, Complete	Air	68.2	19.4

20L COMPLETE UNJACKETED FILTER REACTORS:

Part Number	Description	Motor Type	Overall Height W/ Motor (in)	Clearance Below Valve (in)
CG-1959-F820	20L Process Filter Reactor, Complete	Electric	71.8	19.4
CG-1958-F821	20L Process Filter Reactor, Complete	Air	68	19.4

Standard Components Supplied With Complete Jacketed Filter Reactors:

No.	Part No.	Description
1	CG-2097-16	19mm Stirrer Shaft, 32 3/4" OAL
2a	CG-2077-M-03	19mm PTFE Stir Bearing
2b	CG-2077-M-32	45/50 Lower Joint Adapter
3	CG-149-01	60mm Glass Cap
4	CG-141-T-11	60mm S.S. Clamp, PTFE Coated
5	CG-147-80	60mm Perfluoro O-Ring
6	CG-147-84	200mm Perfluoro O-Ring (2ea)
7	CG-1959-U10 CG-1959-U20	10L Unjacketed Reaction Vessel (CG-1959-F810/F811) 20L Unjacketed Reaction Vessel (CG-1959-F820/F821)
8	CG-1968-66	1" Beaded Pipe Coupling
9a	CG-2033-B-25	Electric Stir Motor, 1/4Hp, 500 RPM
9b	CG-2025-20	Air Motor, 3/8Hp
9c	CG-2025-10	Filter-Regulator-Lubricator (Air Motor Only)
10a	CG-2044-30	19mm Tru-Stir® Shaft Coupling, (Electric)
10b	CG-2044-16	19mm Tru-Stir® Shaft Coupling, (Air)
11	CG-3499-02	10ft Coiled Extension Cord, "T"
12	CG-3498-01	Temperature Monitor, "T"
13	CG-2033-B-50	Stir Motor Controller (Electric Only)
14	CG-3498-03	1/2" OD Rod, 90° Bend
15	CG-9253-10	Universal Kwik Mount Klamp
16	CG-1042-E-10	Thermocouple Adapter, 45/50
17	CG-1946-50	5-Neck Lid, 200mm
18	CG-141-T-15	200mm S.S. Clamp, PTFE Coated (2ea)
19	CG-3498-122 CG-3498-106	1/4" Dia. X 22" Long Thermocouple, "T" (CG-1959-F810/F811) 1/4" Dia. X 26" Long Thermocouple, "T" (CG-1959-F820/F821)
20a	CG-2095-05	5" OD PTFE Agitator, 60° (1ea)
20b	CG-2096-F-08	5" OD PTFE Agitator, 90° (1ea)
21	CG-1959-F200	Filter Support Base, 200mm
22	CG-1965-X-150	Auto-Center Support Frame, 66" OAH
23	CG-1964-A-10	1" Beaded Pipe to 1/2" NPT M, Glass Filled PTFE
24	CG-1959-A-01	Drain Valve, 0-14, 1/2" Swagelock Sidearm
---	CG-1959-F203	200mm PTFE Filter, 30 Micron
---	CG-1963-B-10	Beam Torque Wrench
---	CG-1963-B-14	7/16" Deep Socket, 6 Point, 1/4" Drive

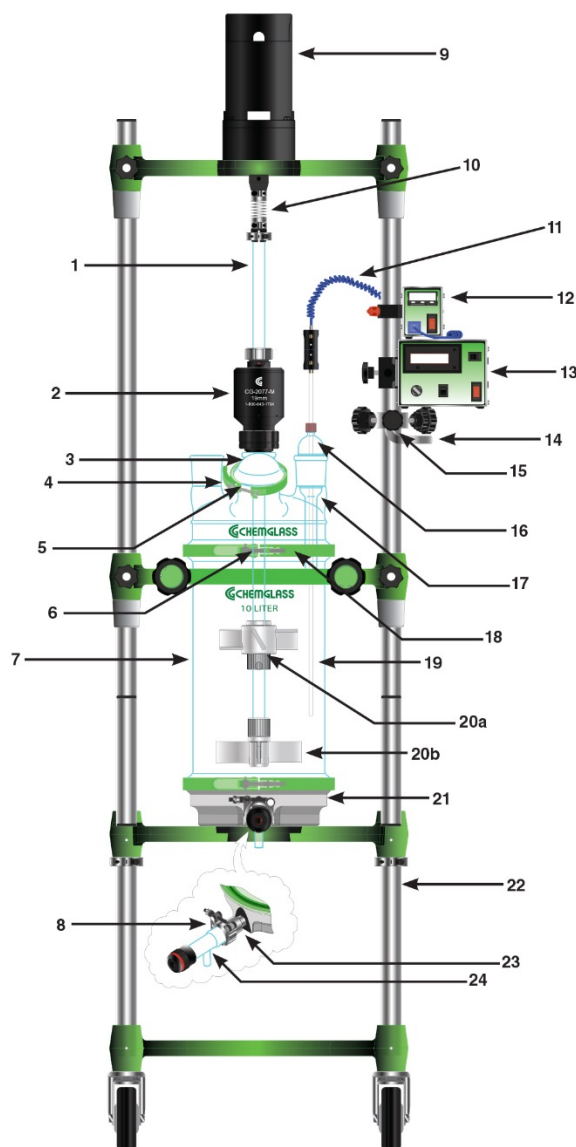

Optional Components:



Safety Shield



Side Support Shelf



Distillation Side Support Shelf



Powder Addition Funnel



Data Logger

CG-1978-P, CG-1979-P and CG-3498 Probes for Reactor Systems Installed in Hazardous/XP or ATEX environments.

Chemglass PT100 and thermocouple probes that will be used in a hazardous/explosion proof area must be used with a Zener barrier.

Zener barriers are used in control and instrumentation systems for the process of standardized signals, such as 20 mA or 10 V. Zener barriers contain intrinsically safe circuits that are to be used to drive intrinsically safe field devices with hazardous area. The manufacturer's data sheets must be consulted. The relevant regulations and directives governing the intended application must be followed. Zener barriers must be installed in conformance with the National Electrical Code. Please check with your company/university.

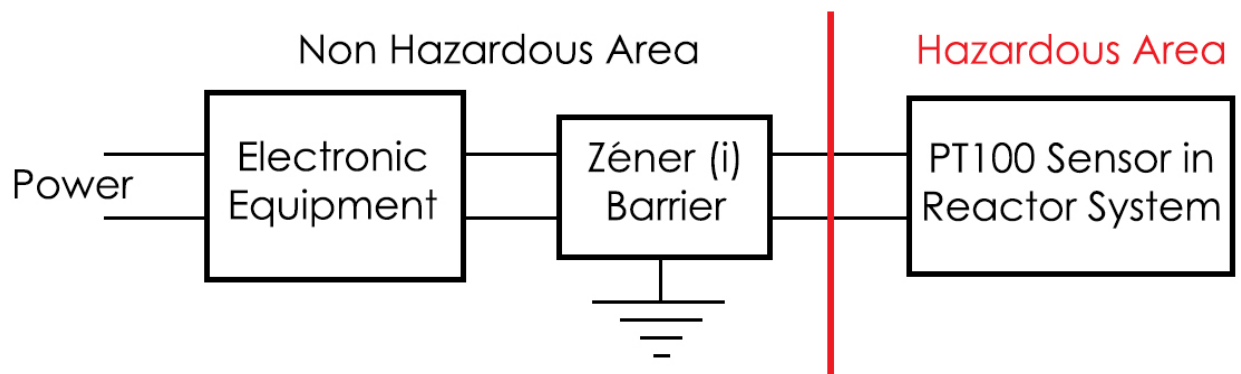

3800 North Mill Road, Vineland, NJ 08360
US & Canada Phone: (800) 843-1794 International: (856) 696-0014
US & Canada Fax: (800) 922-4361 International: (856) 696-9102